

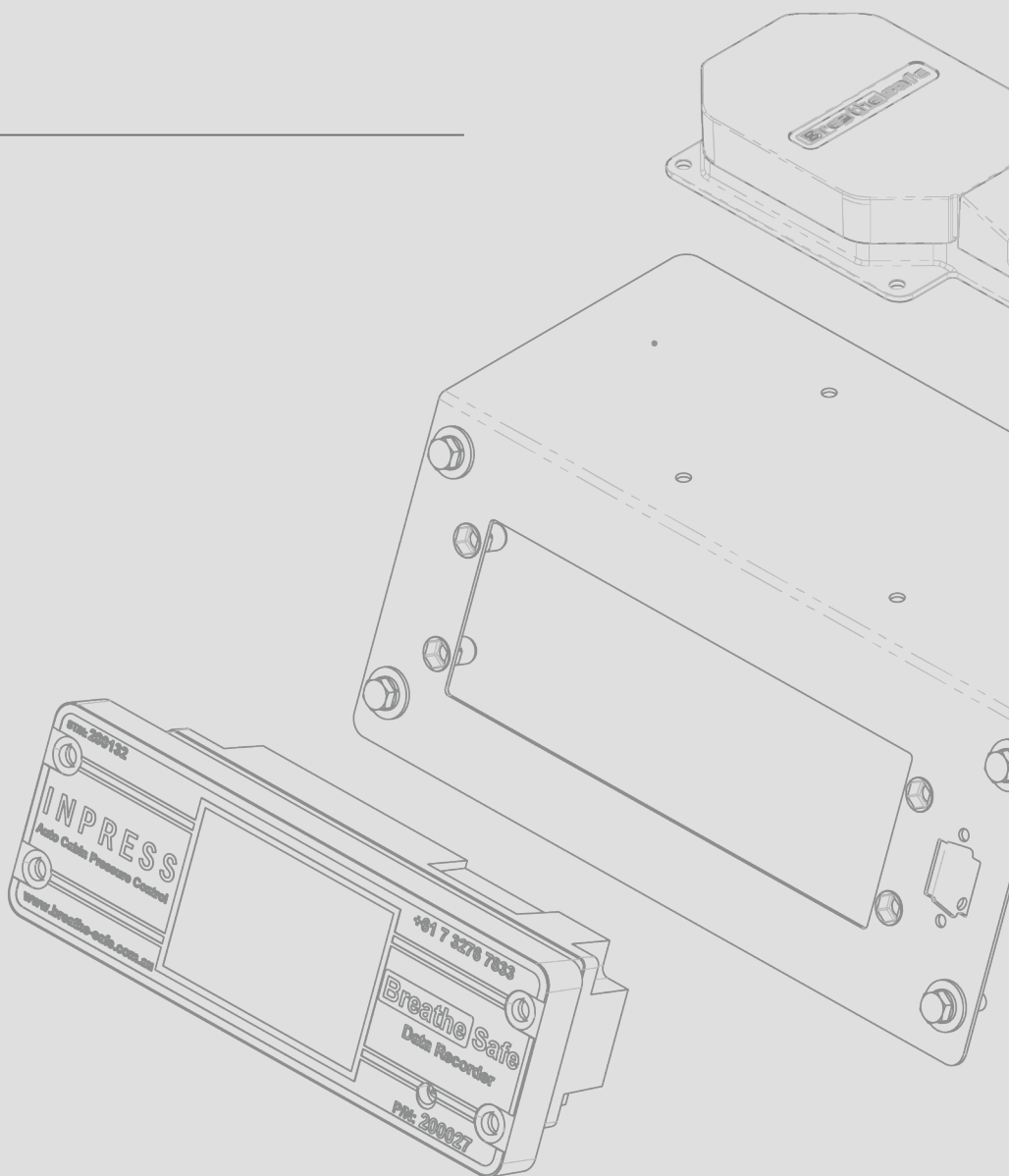

# InPress User Manual

---



# InPress

---

## Contents

### User Guide

Key Features: INPRESS TS

Appearance

Key Features: CO<sub>2</sub> Sensor

### Functions

System Check

To start system check:

To end system check:

### Configurable Settings

User Settings Instructions

Enter Set Up Mode

Set Up Parameters

Pressure Alarm Point

Pressure Alarm Delay

CO<sub>2</sub> Module Enable / Disable

CO<sub>2</sub> Primary Alarm Point

CO<sub>2</sub> Alarm Delay

CO<sub>2</sub> Critical Alarm Mute Reset

Temperature Unit

Temperature Module Enable

Temperature Alarm Point

Temperature Alarm Delay

Service Interval

Standard Logging Interval

Door Alarm Buzzer Setting

Window Alarm Buzzer Setting

Pressure Alarm Buzzer Setting

CO<sub>2</sub> Alarm Buzzer Setting

Temperature Alarm Buzzer Setting

System Change Record

Graphic Display of Change

Start Delay Time Setting

Start Delay Speed Setting

Window Alarm Delay Setting

Door Alarm Delay Setting

Global Alarm Reset Settings

Date Format

Date

Connector Pinout Details

### Wiring

Installation

Warning

### Commissioning Steps

Technical Details

Calibration

### Data Logging Information

Data Download - Setting Up RS232 Connection

INPRESS Controller Set Up

Excel Data Instructions – Unformatted

### Warranty

**3**  
3  
3  
3  
**4**  
5  
5  
5  
**6**  
7  
7  
7  
8  
8  
9  
9  
10  
10  
11  
11  
12  
12  
13  
13  
14  
14  
15  
15  
16  
16  
16  
17  
17  
18  
18  
19  
20  
20  
21  
**22**  
22  
22  
**23**  
23  
24  
**25**  
26  
28  
29  
**30**

# InPress

## INPRESS TS complies with and surpasses ISO 23875, RS20 & ISO10263

### User Guide

The new BreatheSafe INPRESS TS cabin pressure controller specifically designed to monitor, record, and intelligently control the cabin pressure inside a vehicle’s cabin or electrical enclosure. With the optional CO<sub>2</sub> monitoring pod, the INPRESS TS complies with ISO 23875.

Efficient cabin air filtration and pressure management ensure harmful dust and toxic fumes cannot ingress into the cab and be inhaled by operators.

The INPRESS TS has auto pressure control, allowing the end-user to maintain a set cabin pressure easily. RS20 and ISO 23875 recommend over 20Pa if a cabin pressure monitor is installed. BreatheSafe pre-set our systems at 50Pa, with the alarm point being 10Pa.

The controller has a built-in 14-bit digital pressure sensor that accurately measures pressures between 0 and 2000Pa with repeatable accuracy.

An alarm setpoint can be set via the user keypad between the range of 5.0 and 1000Pa. When the pressure within the cabin falls below the alarm setpoint, there will be a (user set) delay, the alarm will sound, and a warning flash on the main screen.

#### Key Features: INPRESS TS

- Digital cabin pressure monitoring system
- Automatic cabin pressure control
- CO<sub>2</sub> monitoring and alerts
- Intelligent fan speed output
- Data logger
- Alarm for low pressure
- Light sensor for automatic dimming of screen

#### Key Features: CO<sub>2</sub> Sensor

- CO<sub>2</sub> Sensor Type is NDIR (Non-Dispersive Infra-red)
- Sample Rate is every 2 seconds
- 12-30V DC Operating Voltage
- Automatic Altitude Compensation
- Alarm Set points are adjustable
- No setup required

### Appearance

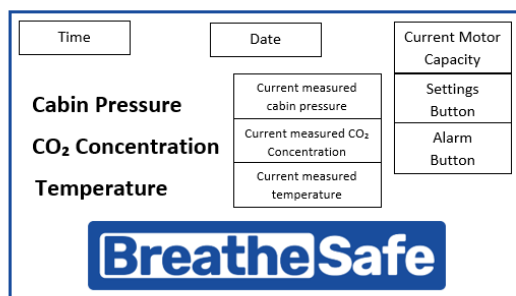
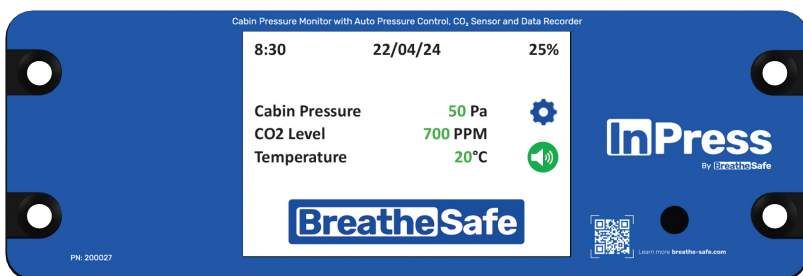

MAIN SCREEN

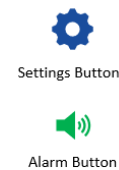

Light Sensor

# InPress

---

## Functions

### Automatic Cabin Pressure

The INPRESS TS is an intelligent pressuriser controller that monitors the pressure difference from inside to outside of the cabin. It controls the speed of the motor to maintain a set pressure difference.

### Low Pressure Alarm

If the cabin pressure falls below the alarm setpoint, INPRESS TS will wait the designated delay time before alarming the user.

The alarm will sound, and 'LOW-PRESSURE WARNING' will flash on screen in red lettering. Press the ALARM button to mute the alarm. At the same time as this alert is sounding, the fan power will increase to maximum to keep operator as safe as possible.

### High CO<sub>2</sub> Concentration Alarm

If the cabin CO<sub>2</sub> concentration rises above the minimum alarm setpoint, INPRESS TS will wait the designated delay time before alarming user. There are two levels of alarms with CO<sub>2</sub> option, a configurable one set at 1000 PPM and a maximum level at 2500 PPM.

The alarm will sound, and a warning will flash on screen in red lettering. Press the ALARM button to mute the alarm. At the same time as this alert is sounding, the fan power will increase to maximum to keep operator as safe as possible.

### Optional High Temperature Alarm

If the internal temperature rises above the alarm setpoint, INPRESS TS will wait the designated delay time before alarming user. The alarm will sound, and a warning will flash on screen in red lettering. Press the ALARM button to mute the alarm.

### Alarm Delay

There is a designated delay time between the TS measuring low pressure and sounding the delay. This gives allowances in time for small changes like opening window briefly. The amount of delay can be changed in settings.

### Service Reminders

The INPRESS TS has automatic reminders for servicing of filter system. The default is 1000 runtime hours but can be altered in settings.

### Data Logging

By default, the BreatheSafe INPRESS TS unit starts data logging as soon as power is applied. This feature cannot be stopped or disabled.

Data logging records time, date, pressure reading, any configurable changes made, and any alarms activated during operation.

### Light Sensor

The light sensor automatically adjusts screen brightness for operator safety and minimised distraction.

### Graphic Display of System and Data Changes

A table display is available for a visual representation of the pressure inside cabin, alarms, fan voltage, setpoint and other setting changes, since turned on. See page 15 for more.

# InPress

## System Check

To check to see if the INPRESS TS is installed correctly, press the 'SYSTEM CHECK' button to enter the Test Max Output screen. This will bring you back to what looks like the Main Screen with "System Test – Max Fan" displayed on screen.

The fans will run at max speed and allow operator to see pressure inside of the cabin. The effectiveness of the Pressuriser is dependent on how well the cabin is sealed. We recommend 250Pa max pressuriser speed from new.

Any leaks or ineffective cabin sealing will reduce the pressure at max speed, indicating adjustments required.

To end system check, press the settings cog button. Then, select the CANCEL SYSTEM CHECK button. This will return system to normal operation.

Notes for new cabin or a cabin with new seals: Open a window slightly before closing entrance door to vent static air pressure inside of the cabin. When entrance door is fully closed then close the window to begin the test.

### To start system check:

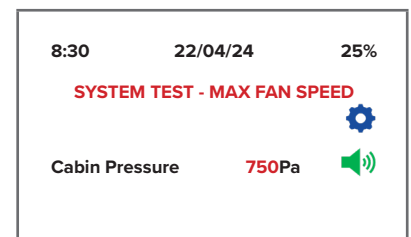
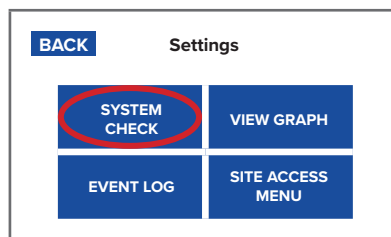
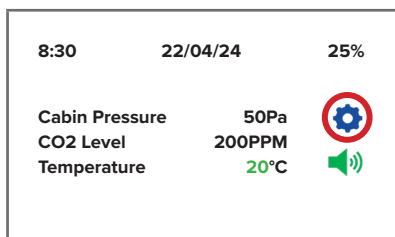

### To end system check:

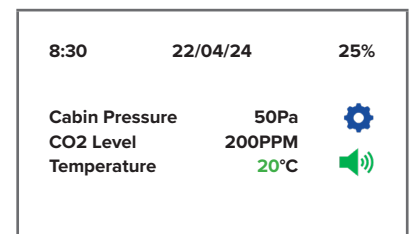
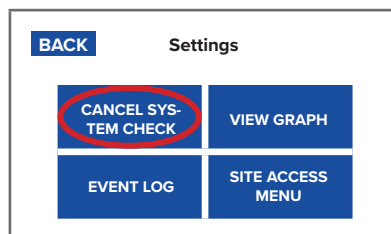
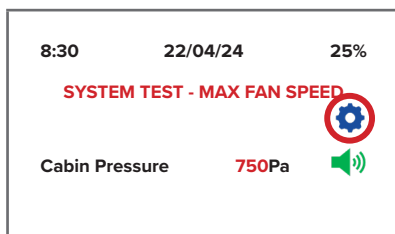

# InPress

---

## Configurable Settings

### Pressure Settings

Pressure Unit  
Pressure Set Point  
Pressure Alarm Point  
Pressure Alarm Delay

### CO<sub>2</sub> Settings

CO<sub>2</sub> Module Enable  
CO<sub>2</sub> Primary Alarm Point  
CO<sub>2</sub> Alarm Delay  
CO<sub>2</sub> Critical Alarm Mute Reset

### Temperature Settings

Temperature Unit  
Module Enable  
Alarm Point  
Alarm Delay

### Service Interval Settings

### Standard Logging Interval Settings

### Alarm Buzzer Settings

Door Alarm Buzzer Setting  
Alarm Buzzer Setting  
Alarm Buzzer Setting  
Primary Buzzer Setting  
Temperature Alarm Buzzer Setting

### System Change Record

### Start Delay Settings

Start Delay Time  
Start Delay Speed

### Alarm Delay Settings

Window Alarm Delay  
Door Alarm Delay

### Global Alarm Reset Settings

### Date Settings

Date Format – 20 Date – 20

### Important Pins

Site Pin: 7597  
Clear Log Pin: On request - please call +61 07 3276 7833

## User Settings Instructions

### Enter Set Up Mode

Start-Up Screen > Main Screen > Settings Button > Settings Screen > Site Access Button > Insert Pin > Site Menu

To enter the Setup mode, press the SETTING button.  
Then enter SITE ACCESS MENU. Type in 4-number pin and press ENTER.  
Pin: 7597

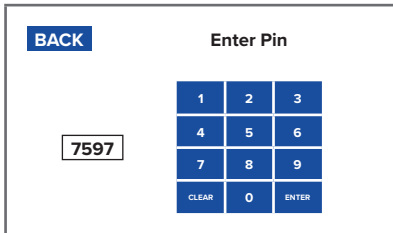

### Set Up Parameters

Placing the BreatheSafe 200027 unit into Setup mode allows the adjustment of the following parameters:

- Time (hours/minutes/seconds)
- Date (day/month/year)
- Pressure alarm setpoint
- Preferred cabin pressure
- Alarm delay/ intervals of alarm
- Calibration and system settings
- Resetting of the data logging
- Service reminders interval gap
- Reset current runtime between services
- CO2 settings and alarms

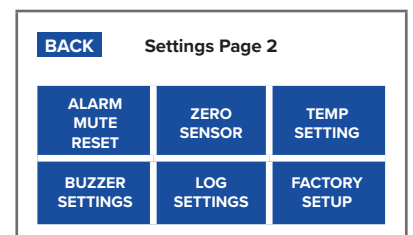
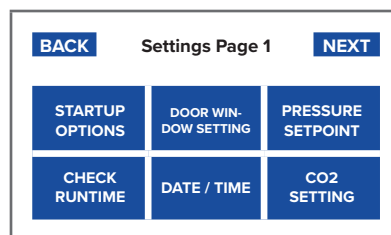
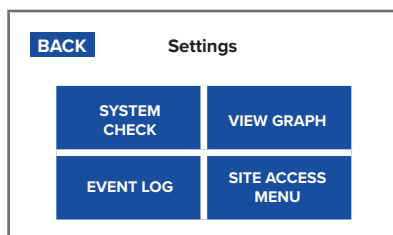

## Pressure Alarm Point

Set the point that the alarm will sound when pressure of the cabin reaches a certain internal pressure. Alarm Setpoint changes the appointed pressure that sets the alarm off. Low pressure can allow hazardous particles into the cab and can occur when doors or windows are left open, or if there is an issue with the sealing. Enter Setup mode and select ADJUST SETPOINT button. Use the onscreen UP and DOWN buttons to change the corresponding fields.

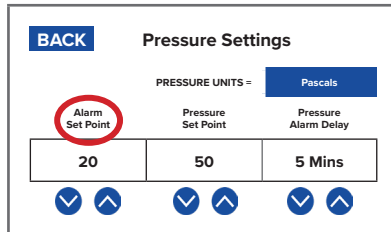
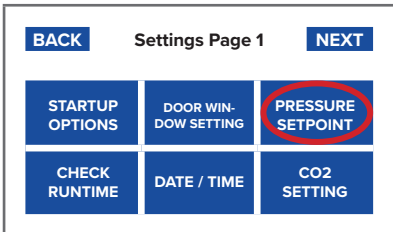
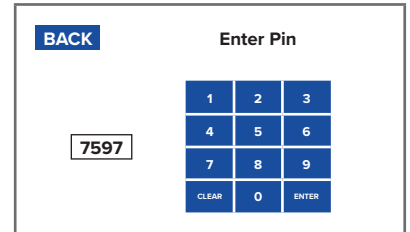
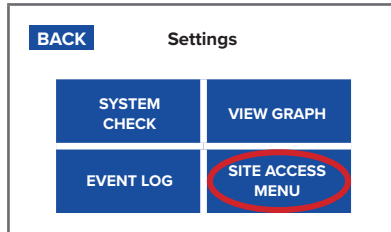
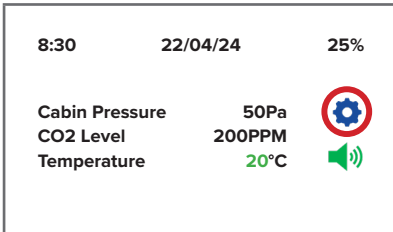

## Pressure Alarm Delay

After pressure within the cabin reaches the setpoint, the alarm will sound after the designated amount of time. The Alarm Delay adjusts the length of time between the INPRESS TS measuring low pressure and sounding the alarm. Low pressure can occur when a door or window is opened momentarily, not requiring alarm to sound. Use the onscreen ADJUST buttons to change the corresponding fields. Press to toggle through Disabled / 1- 10 minutes.

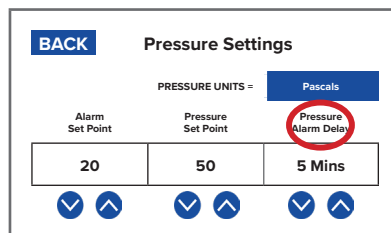
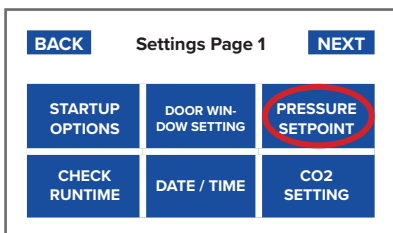
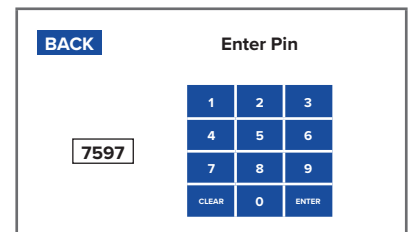
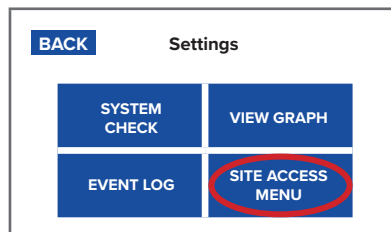
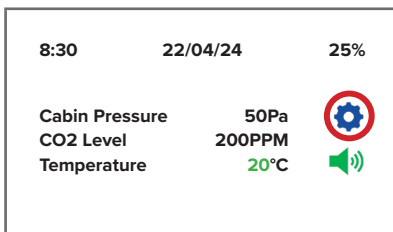



# InPress

## CO<sub>2</sub> Module Enable / Disable

Enable or disable to CO<sub>2</sub> module used for measuring CO<sub>2</sub> levels within the cabin.

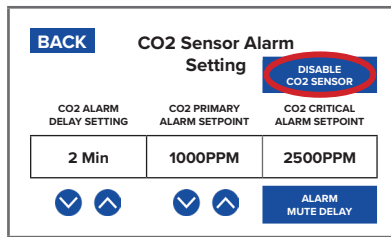
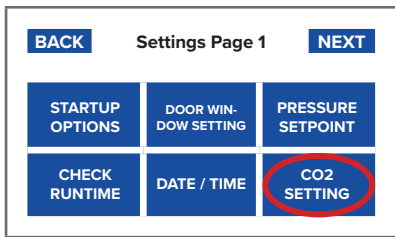
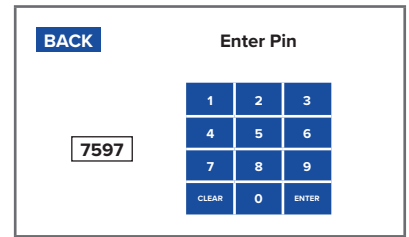
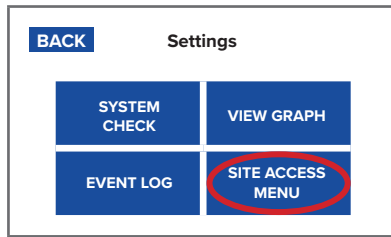
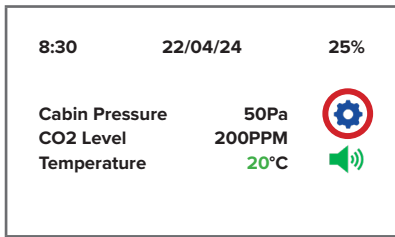

## CO<sub>2</sub> Primary Alarm Point

The first alarm will sound when CO<sub>2</sub> levels inside the enclosure reach this point.

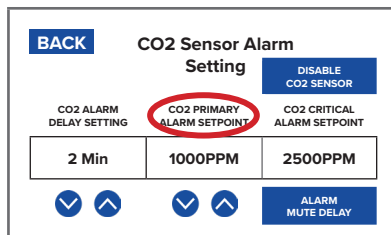
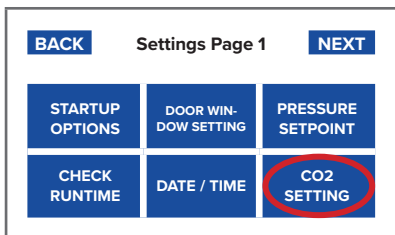
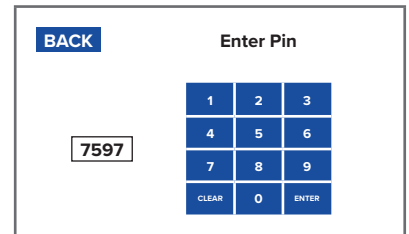
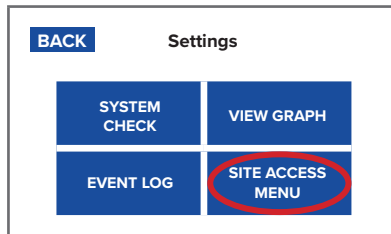
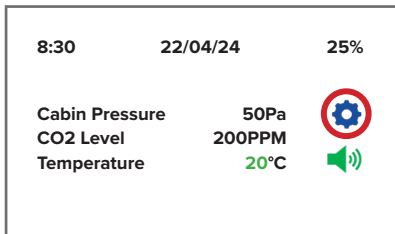

# InPress

## CO<sub>2</sub> Alarm Delay

After CO<sub>2</sub> (concentration in ppm) within the cabin reaches the 1000 ppm setpoint, the alarm will sound after this designated amount of time. The Alarm Delay adjusts the time between the INPRESS TS measuring CO<sub>2</sub> concentration and sounding the alarm. Use the onscreen ADJUST buttons to change the corresponding fields. For example, press to toggle through Disabled / 1 – 10 minutes.

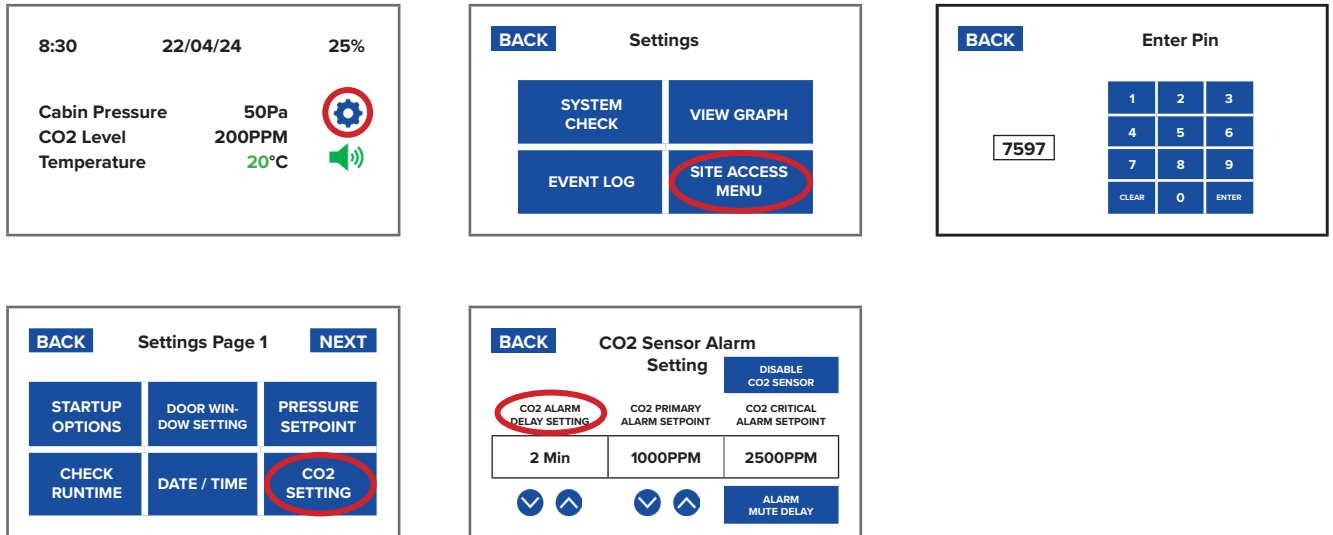

## CO<sub>2</sub> Critical Alarm Mute Reset

The critical alarm is set at 2500 PPM and cannot be changed. The mute delay, however, can be configured.

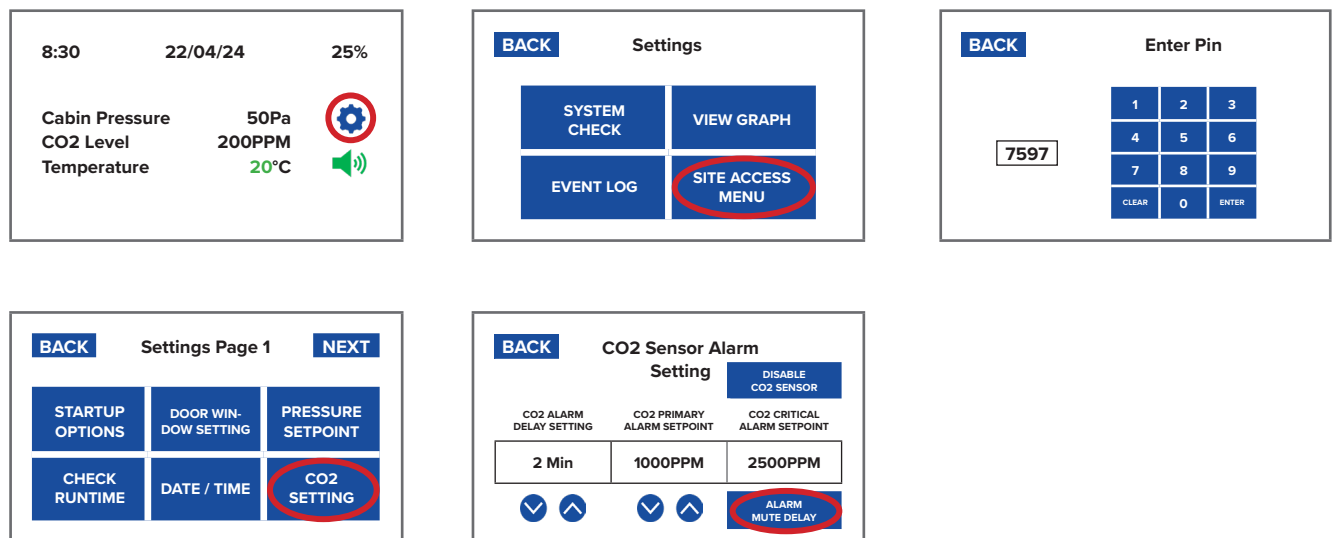

## Temperature Unit

Change the temperature unit between Fahrenheit and Celsius.

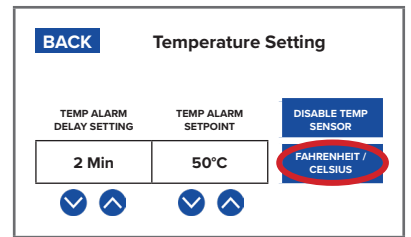
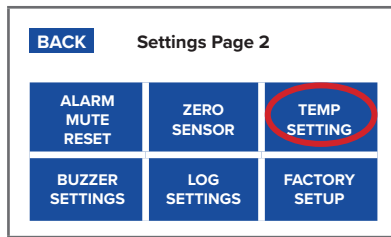
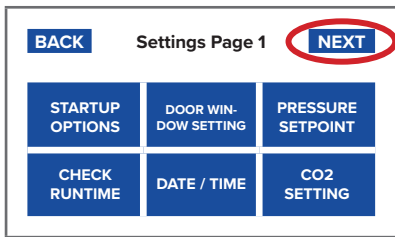
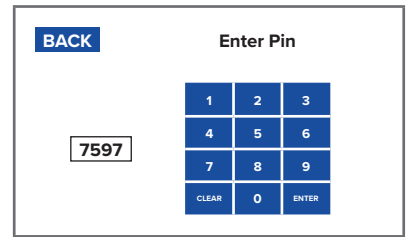
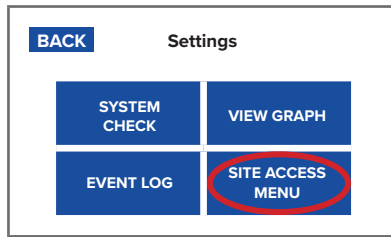
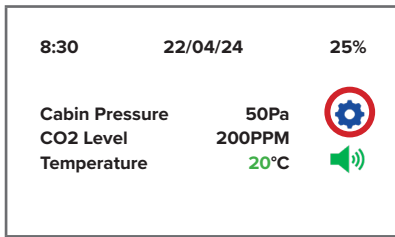

## Temperature Module Enable

Enable whether temperature will be measured or recorded.

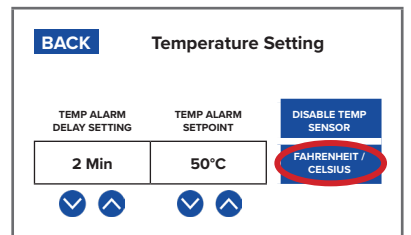
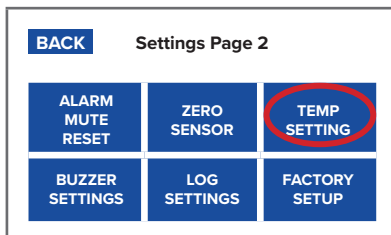
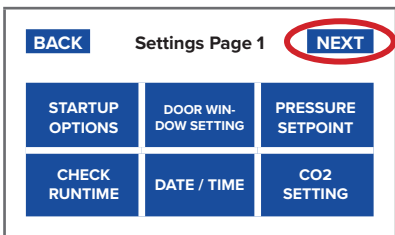
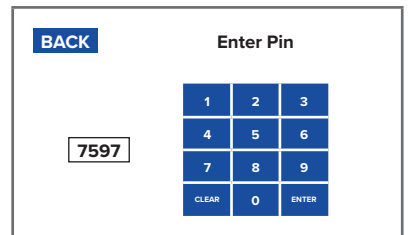
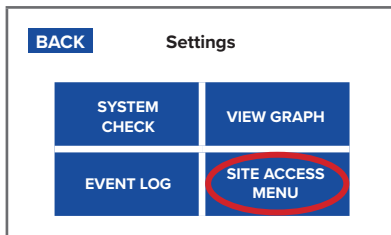
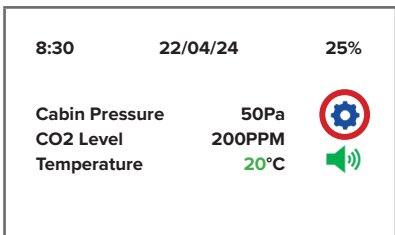

# InPress

## Temperature Alarm Point

Alarm Setpoint changes the appointed temperature that sets the alarm off. High temperature can be dangerous for operators and machinery.

Use the onscreen UP and DOWN buttons to change the corresponding fields.

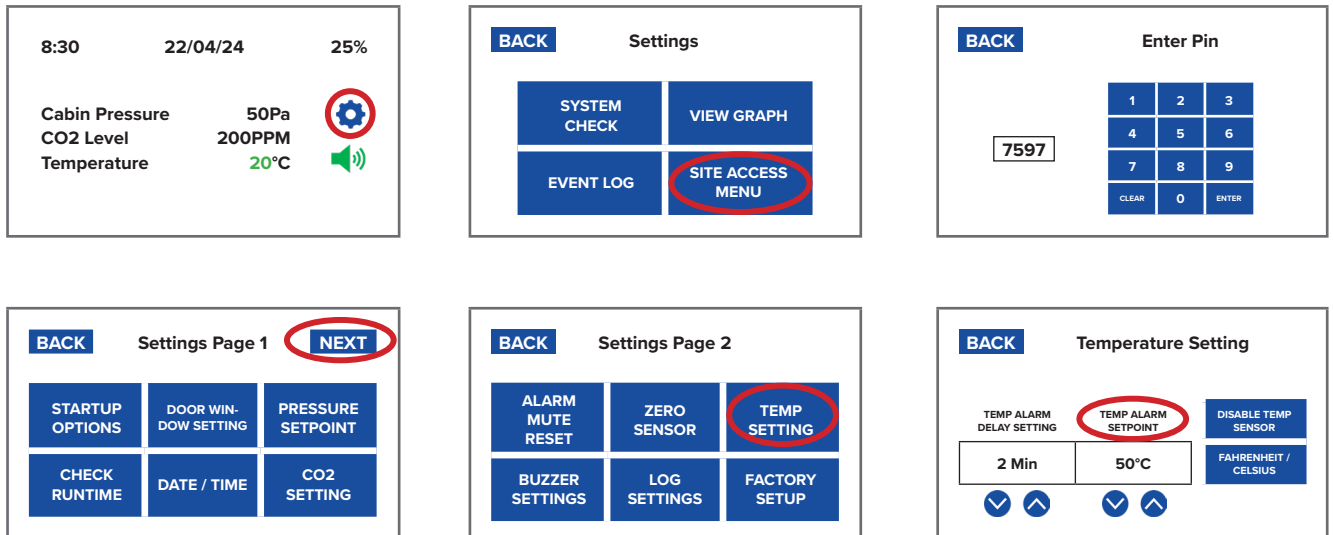

## Temperature Alarm Delay

The Alarm Delay adjusts the length of time between the INPRESS TS measuring high temperature and sounding the alarm.

Use the onscreen ADJUST buttons to change the corresponding fields. Press to toggle through Disabled / 1-10 minutes.

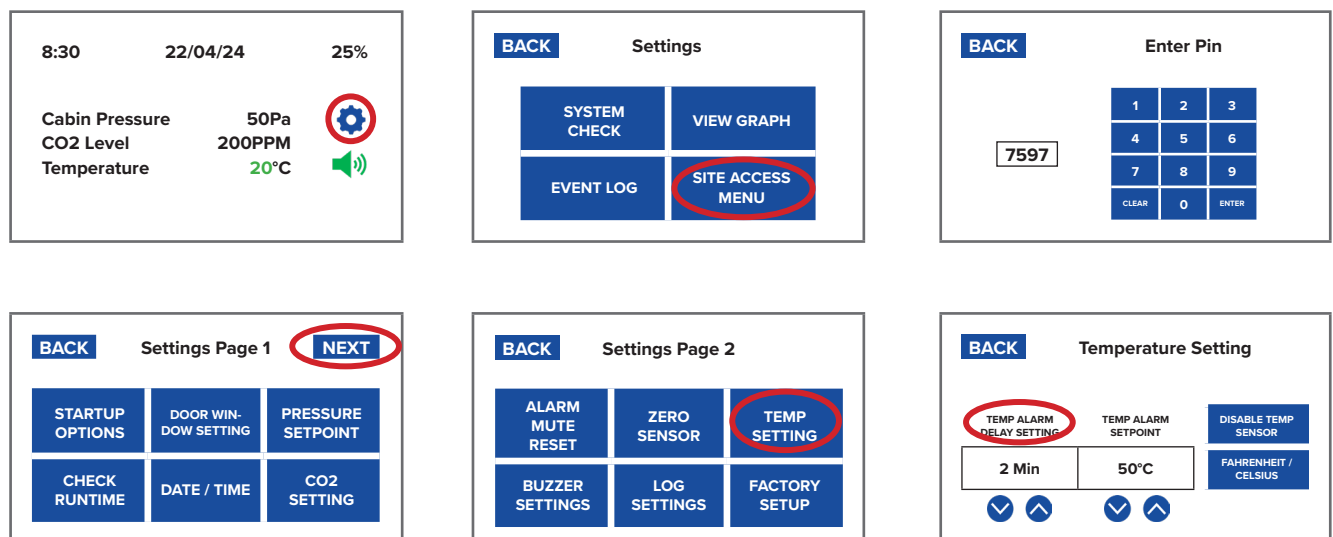

# InPress

## Service Interval

Use the onscreen UP and DOWN buttons to change the service interval setpoint.

To reset the current runtime to zero, press the RESET CURRENT RUNTIME button and enter the site access pin.

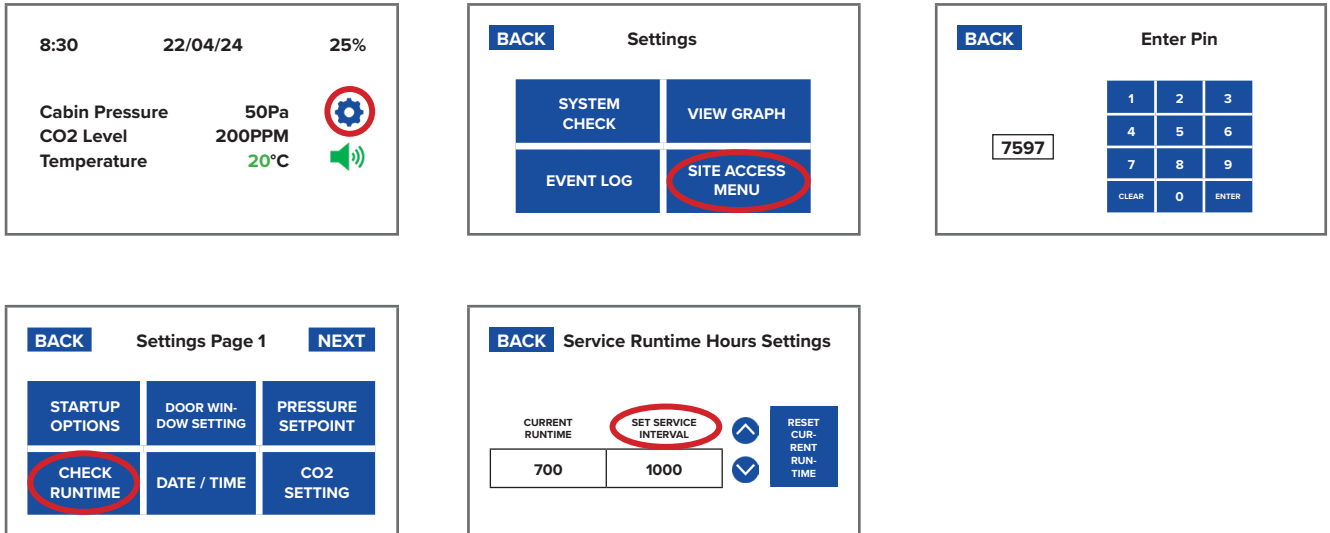

## Standard Logging Interval

By default, the BreatheSafe INPRESS TS unit starts data logging as soon as power is applied. This feature cannot be stopped or disabled. Data logging records time, date, pressure reading, turbine motor capacity, and any alarms activated during operation.

This setting will change how often the logging occurs.

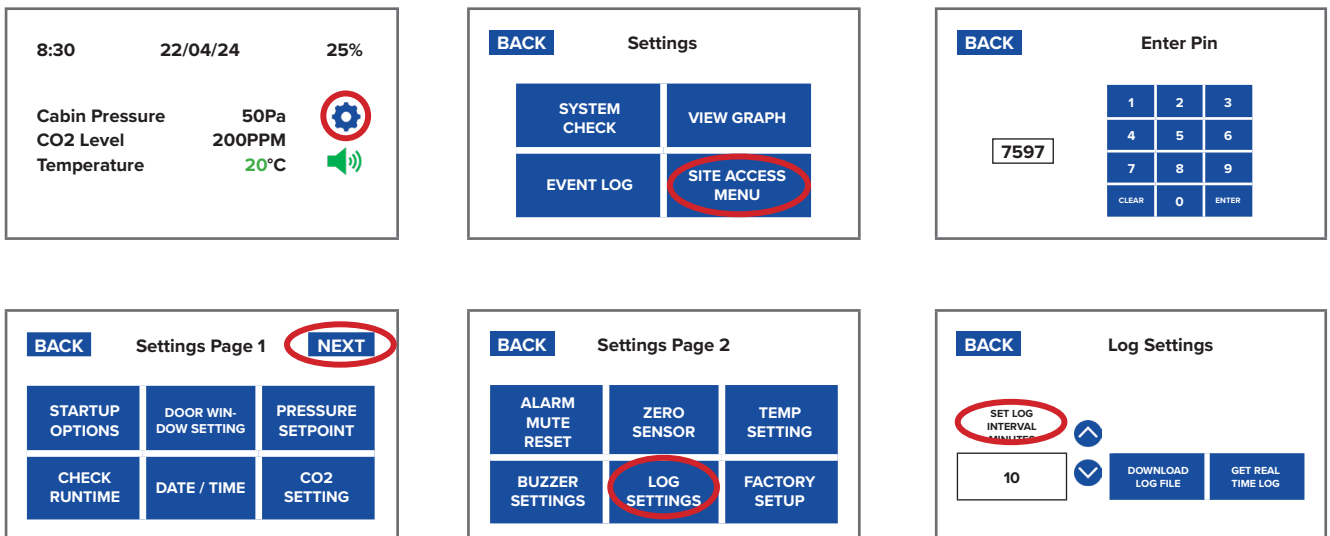

# InPress

## Door Alarm Buzzer Setting

If enabled and connected, the INPRESS TS will alert the operator if the door is not shut.

To disable buzzer, toggle through ENABLED and DISABLED button.

The screenshots show the navigation path to disable the door alarm buzzer:

- Home Screen:** Displays cabin pressure (50Pa), CO2 level (200PPM), and temperature (20°C). A gear icon indicates settings are available.
- Settings Menu:** The 'SITE ACCESS MENU' option is highlighted.
- Enter Pin:** The PIN '7597' is entered.
- Settings Page 1:** The 'NEXT' button is highlighted.
- Settings Page 2:** The 'BUZZER SETTINGS' option is highlighted.
- Alarm Buzzer Setting:** The 'DOOR BUZZER' is currently set to 'ENABLED'. The 'DISABLED' button is highlighted as the target for the next step.

## Window Alarm Buzzer Setting

If enabled and connected, the INPRESS TS will alert the operator if window is not shut.

To disable buzzer, toggle through ENABLED and DISABLED button.

The screenshots show the navigation path to disable the window alarm buzzer:

- Home Screen:** Displays cabin pressure (50Pa), CO2 level (200PPM), and temperature (20°C). A gear icon indicates settings are available.
- Settings Menu:** The 'SITE ACCESS MENU' option is highlighted.
- Enter Pin:** The PIN '7597' is entered.
- Settings Page 1:** The 'NEXT' button is highlighted.
- Settings Page 2:** The 'BUZZER SETTINGS' option is highlighted.
- Alarm Buzzer Setting:** The 'WINDOW BUZZER' is currently set to 'ENABLED'. The 'DISABLED' button is highlighted as the target for the next step.

## Pressure Alarm Buzzer Setting

To disable buzzer, toggle through ENABLED and DISABLED button.

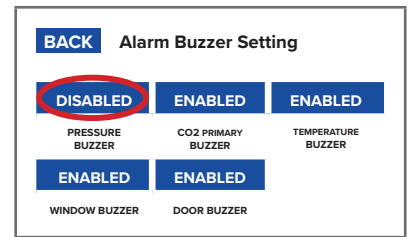
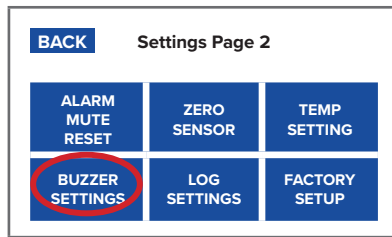
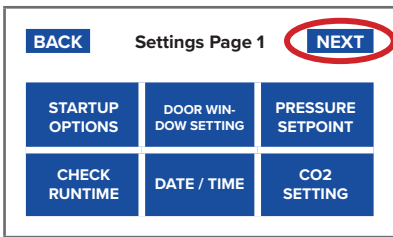
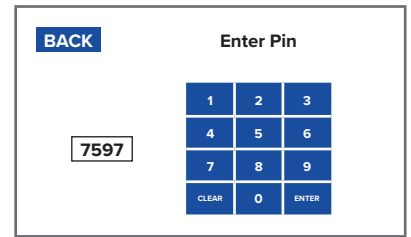
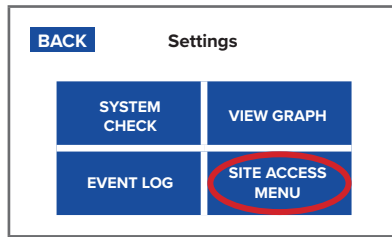
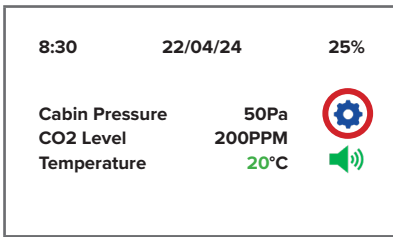

## CO<sub>2</sub> Alarm Buzzer Setting

To disable buzzer, toggle through ENABLED and DISABLED button.

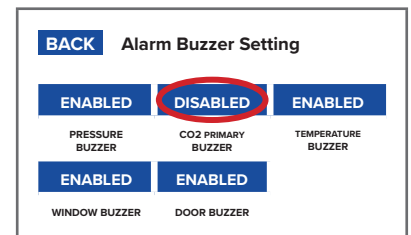
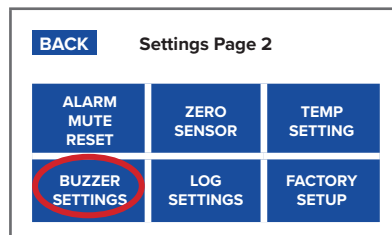
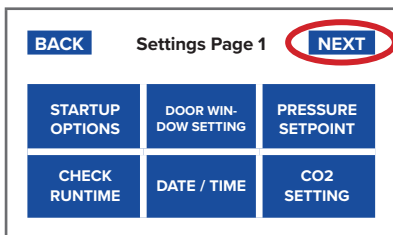
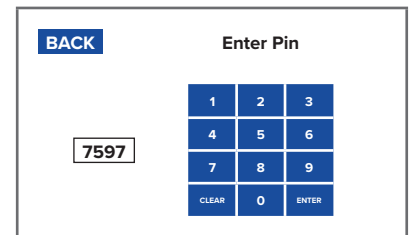
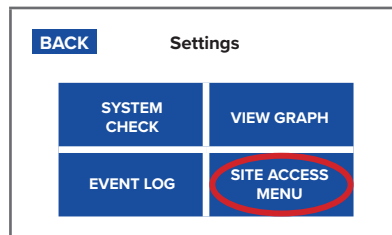
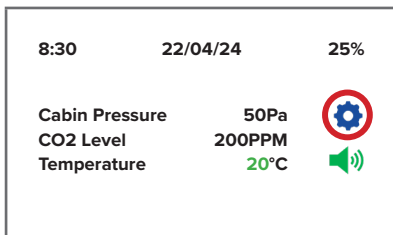

## Temperature Alarm Buzzer Setting

To disable buzzer, toggle through ENABLED and DISABLED button.

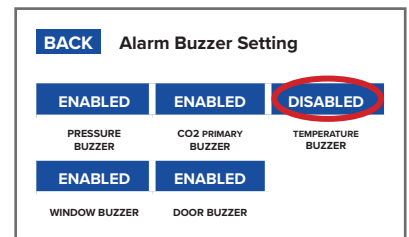
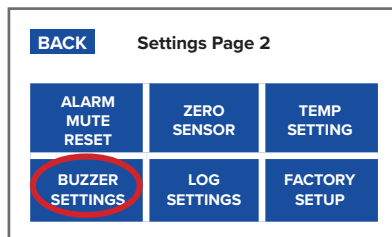
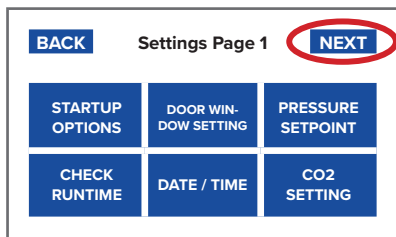
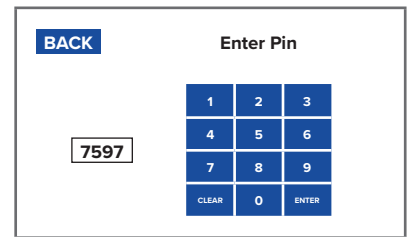
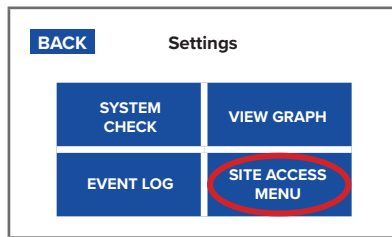
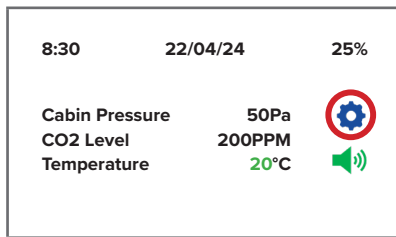

## System Change Record Graphic Display of Change

The INPRESS records whenever settings of INPRESS are reconfigured and is presented in table and graph. This table and graph is also available data along with a visual representation of the pressure inside cabin, alarms, motor voltage, setpoint, and other setting changes. It records since device is turned on.

Date	Time	Press.	CO2	Temp	Fan	Event
22/04/24	16:52	0050	0974	24	39	System Shutdown
22/04/24	16:58	0051	1072	24	38	Max Press. Deactivated
22/04/24	16:52	0492	0861	24	100	Max Press. Activated
22/04/24	16:47	0051	0880	24	32	Alarm Mute Activated
22/04/24	16:44	0051	1481	24	34	CO2 Primary Alarm
22/04/24	16:32	0051	0884	24	36	System Started
22/04/24	14:35	0008	0817	24	100	System Shutdown
22/04/24	13:41	0012	0798	24	100	Alarm Mute Activated
22/04/24	13:38	0050	0812	24	100	Low Pressure Alarm ON
22/04/24	12:38	0050	0842	24	32	System Started
22/04/24	11:31	0049	0638	24	34	System Shutdown
22/04/24	10:43	0052	0861	24	89	Alarm Mute Activated
22/04/24	10:41	0050	0880	24	32	Low Pressure Alarm ON

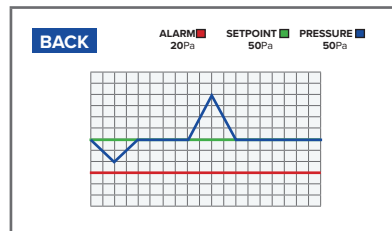

Date	Time	Press.	CO2	Temp	Fan	Event



# InPress

## Start Delay Time Setting

The Alarm Delay adjusts the length of time between the INPRESS TS starting up and the unit controlling pressure. Factory default is run for 10 mins on 30% capacity before going to full auto control mode.

Use the onscreen ADJUST buttons to change the corresponding fields. Press to toggle through Disabled / 1 – 10 minutes.

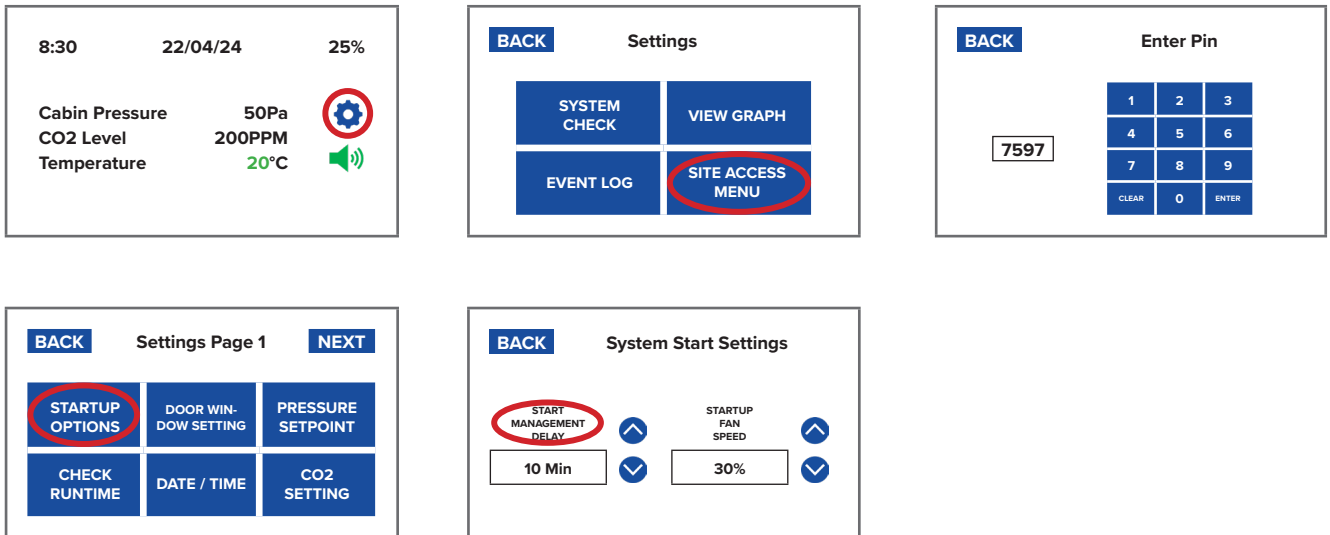

## Start Delay Speed Setting

The Start Delay Speed setting adjusts the speed that the motor runs at during the delayed start period. Factory default is 30% before it starts auto pressure control mode.

Use the adjust buttons to adjust both the delay period 1/10 minutes and the motor capacity 16% to 100%.

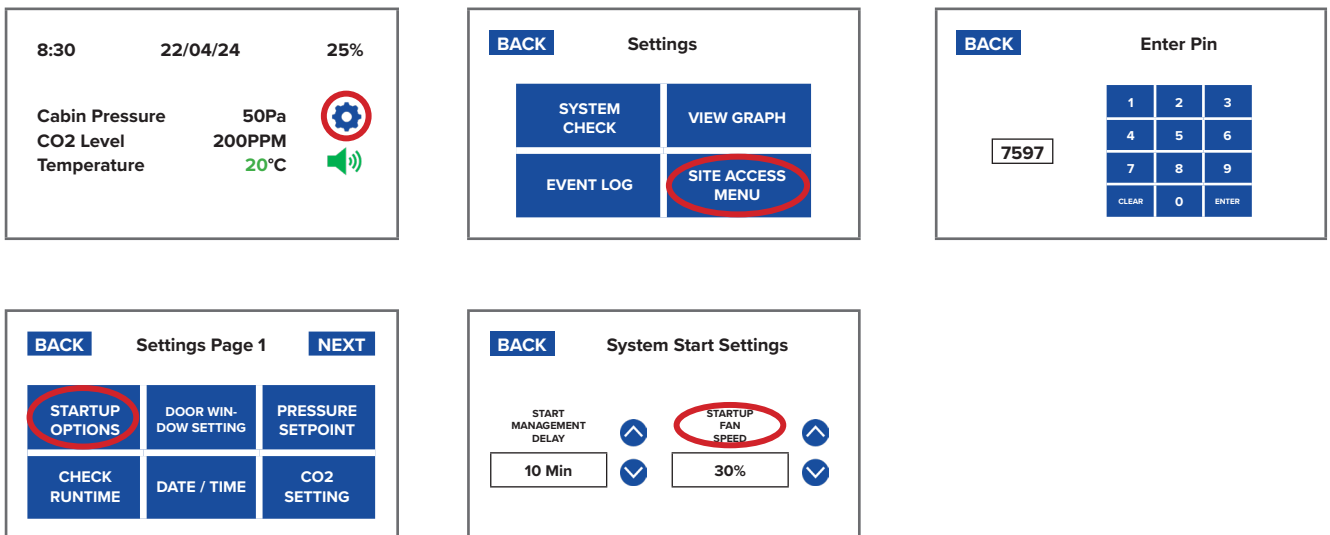

## Window Alarm Delay Setting

The Alarm Delay adjusts the length of time between the INPRESS TS sensing an open or faulty window and sounding the alarm. The door sensor can be triggered when a window is opened momentarily, not requiring alarm to sound. Setting a delay between sensing the window and sounding the alarm allows for usual window usage which does not require an alarm to sound. Use the onscreen ADJUST buttons to change the corresponding fields. Press to toggle through Disabled / 1 – 10 minutes.

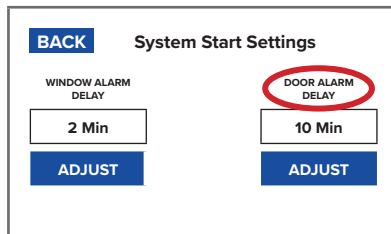
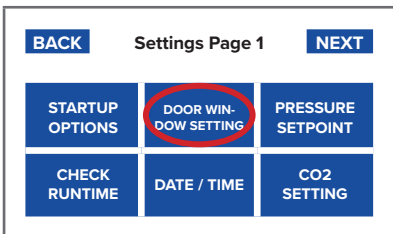
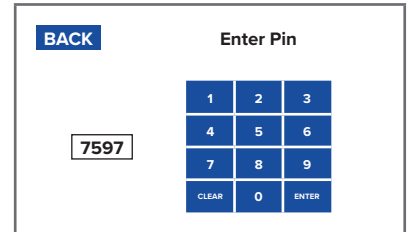
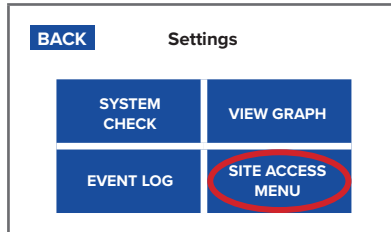
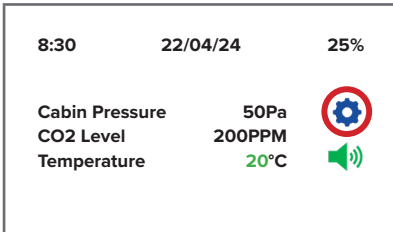

## Door Alarm Delay Setting

The Alarm Delay adjusts the length of time between the INPRESS TS sensing an open or faulty door and sounding the alarm. The door sensor can be triggered when a door is opened momentarily, not requiring the alarm to sound. Setting a delay between sensing the door and sounding the alarm allows for usual door usage which does not require an alarm to sound. Use the onscreen ADJUST buttons to change the corresponding fields. Press to toggle through Disabled / 1 – 10 minutes.

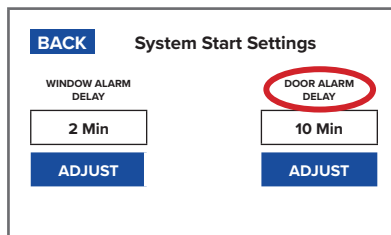
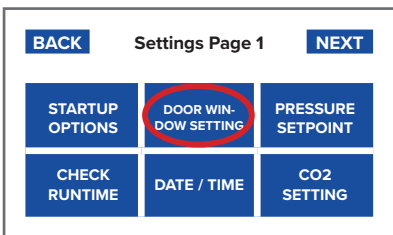
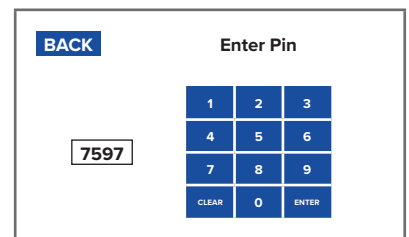
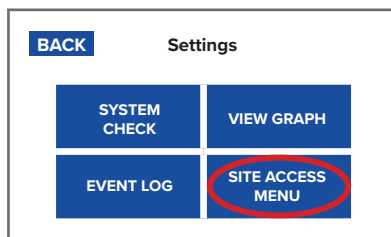
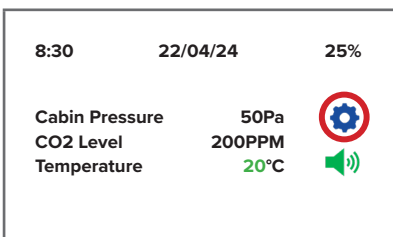

## Global Alarm Reset Settings

Once an alarm has been activated it can be muted for a pre-set time (this will still show on the display). After that pre-set time, the function will reactivate.

If the alerting event is still present, the system will alarm again.

This setting configures this reactivation period.

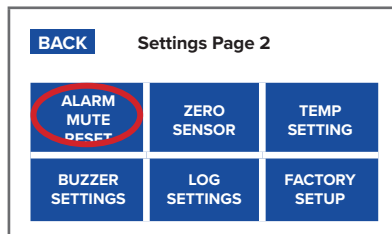
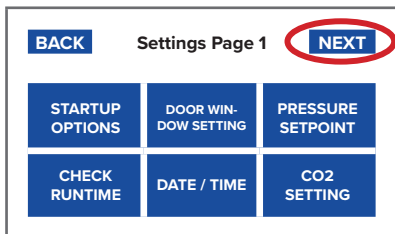
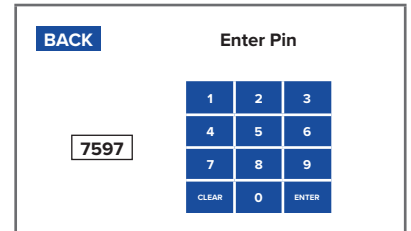
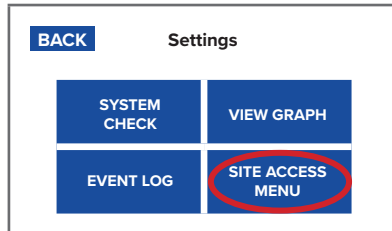
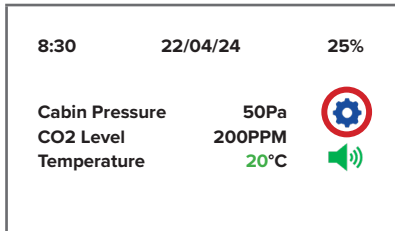

# InPress

## Date Format

Change the date format between DDMMYYYY and MMDDYYYY.

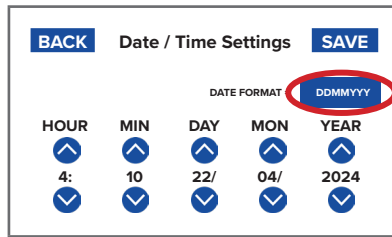
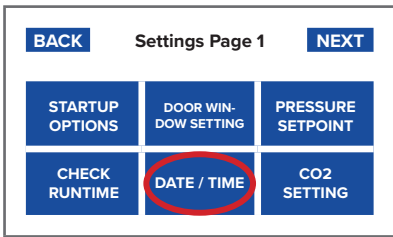
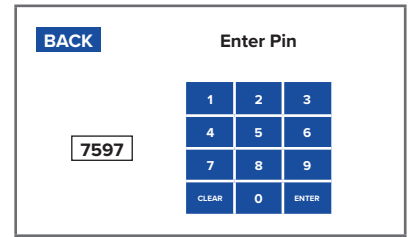
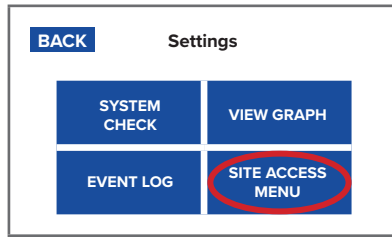
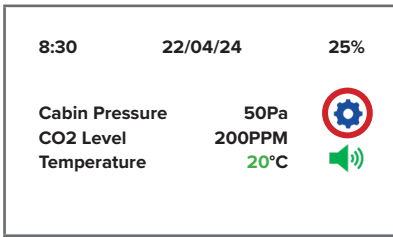

## Date

Change the recorded date displayed and measured by the InPress.

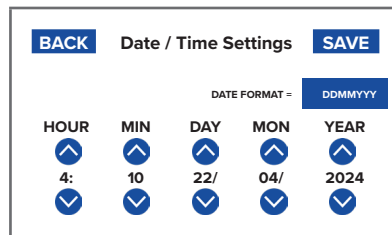
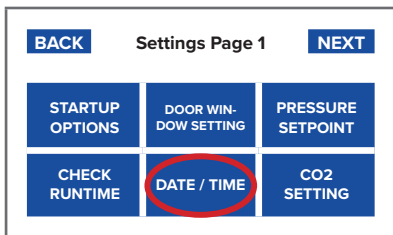
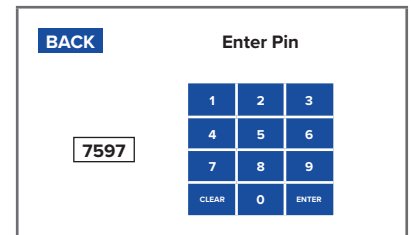
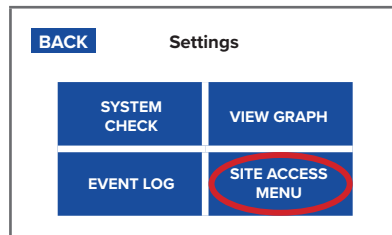
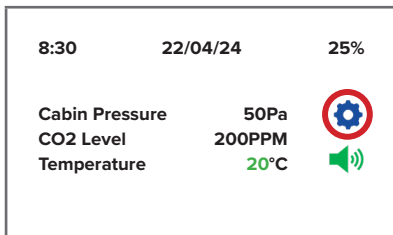

## Connector Pinout Details

Item	Pin	Destination
1	Pin 1	12 / 24 Volt Positive Supply
2	Pin 2	Can H Option
3	Pin 3	Can L Option
4	Pin 4	Serial Transmit RS232 Door Load
5	Pin 5	Motor Control Volts Out
6	Pin 6	Alarm + Output
7	Pin 7	Temperature Sensor
8	Pin 8	No Connection
9	Pin 9	Serial Receive RS232
10	Pin 10	Door Input (+)
11	Pin 11	Window Input (+)
12	Pin 12	0V Negative Ground

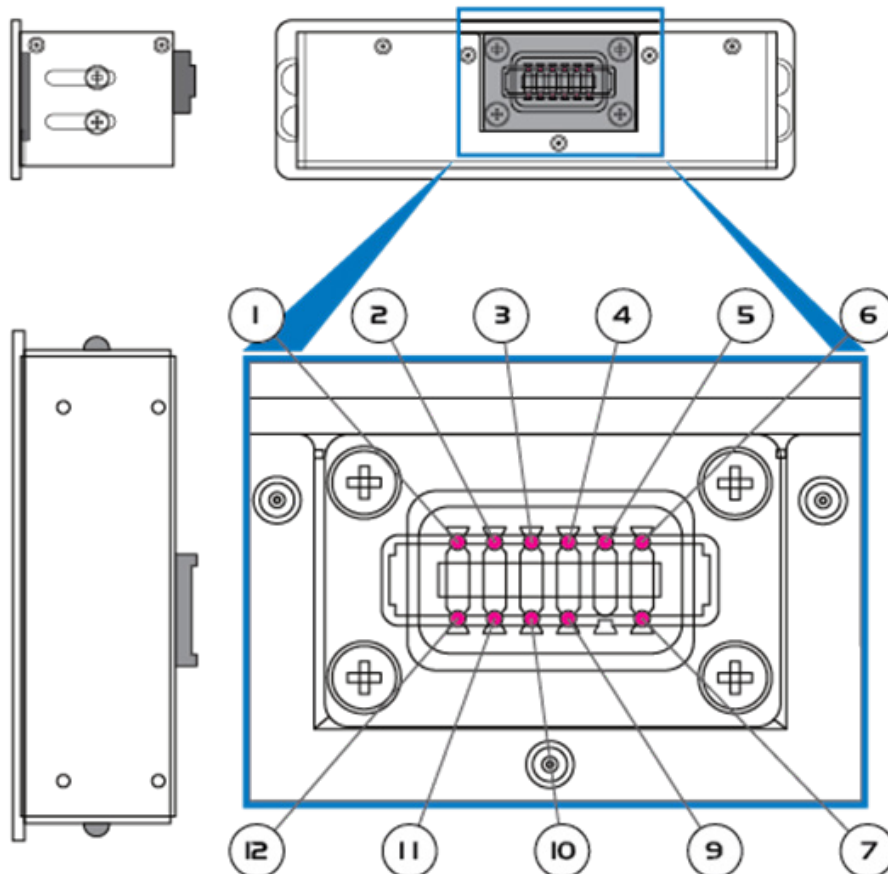

## Wiring

### INPRESS TS User Interface (UI)

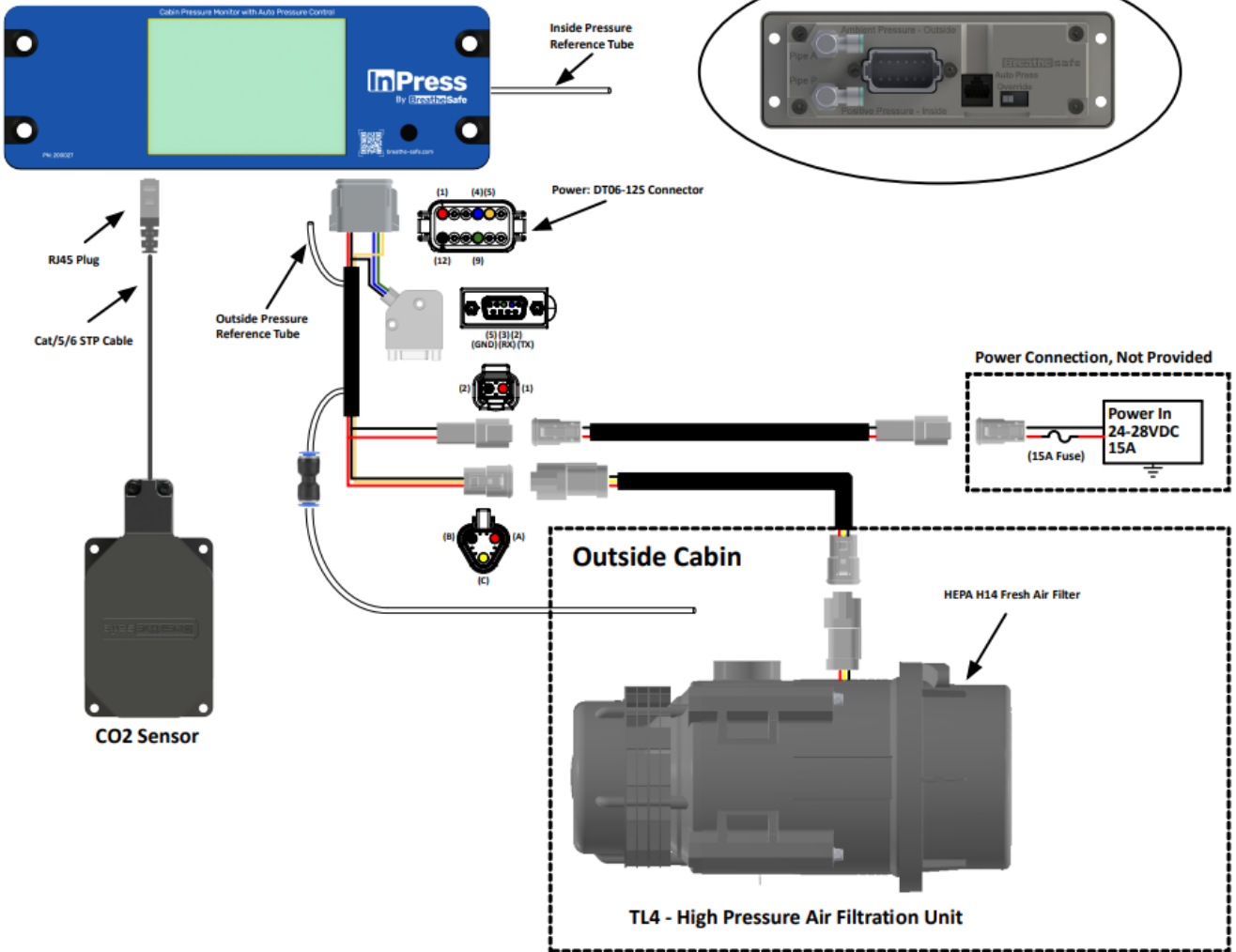

## Installation

### Warning

Qualified staff must wear the correct personal protective equipment when cleaning and servicing this unit due to hazardous dust and fibres which may be caught by the stages of air filtration during normal unit operation.

The electrical power system is supplied by 12v DC or 24v DC and no work should be carried out on the pressuriser system without the correct safe work procedures and electrical safety measures being taken, and all relevant circuit breakers opened to isolate the circuit. The air filtration system may have several types of highspeed rotating equipment installed with very sharp edges. Ensure all safety guards are in place while the system is running.

# InPress

---

## Commissioning Steps

To determine if installed correctly, follow the following steps:

1. Power up the pressuriser and ensure fan/s are operating correctly.
2. Make sure the pressuriser switches on / off with ignition.
3. Check pressure under max fan speed.

Start Up Screen > Main Screen > System Check Set Button > Test Max Output

To check to see if the INPRESS is installed correctly, press the SYSTEM CHECK SET MAX button to enter the Test Max Output screen. This will bring you back to what looks like the Main Screen with “System Test – Max Fan” displayed on screen.

The Fans will run at max speed and allow operator to see pressure inside of the cabin. The effectiveness of the Pressuriser is dependent on how well the cabin is sealed. We recommend 250Pa max pressuriser speed from new.

Any leaks or ineffective cabin sealing will reduce the pressure at max speed, indicating adjustments required.

Notes for new cabin or a cabin with new seals: Open a window slightly before closing entrance door to vent static air pressure inside of the cabin. When entrance door is fully closed then close the window to begin the test.

## Technical Details

### Fan Speed Control Output

The BreatheSafe INPRESS TS controller automatically adjusts the turbine motor to maintain a pre-set cabin pressure based on the unit’s pressure set-point.

The TS unit monitors the cabin pressure as measured through its built-in pressure transducer and calculated the error based on the pressure setpoint. This value is applied to an algorithm and the controller calculates a proportional output which adjusts the speed of the pressuriser motor.

### Mounting

The TS unit is designed to be dashboard mounted and utilises a proprietary housing to secure the unit. Mounting can be in any orientation, preferably internally and positioned such that the operator can monitor the cabin pressure, ensuring their working environment is safe.

### Supply Power

The BreatheSafe INPRESS TS unit is designed to operate via the vehicle’s ignition key-switch. The unit becomes fully operational approximately 5 seconds after turning the ignition on.

It is advisable to install an inline fuse rated at 5A maximum for added protection up to the unit’s connector. The unit is fully protected against reverse power for an indefinite period.

The operating voltage is in the range of 12V to 36V DC and the power supply is designed specifically to operate in the harsh vehicle environments, which may include battery jump starts and battery chargers. The door and window digital inputs operate in the range of 12 to 24V DC commensurate with the vehicle’s power supply.

## InPress

---

### Calibration

The BreatheSafe INPRESS TS controller is fully digital and should not require further calibration or setting up. The unit becomes fully operational approximately 5 seconds after being switched on.

For added peace of mind, auto calibration is available under the Zero Sensor section.

Please do not attempt to open this unit and tamper with it as there are no user serviceable parts inside and you may cause it irreparable damage in the process.

### Control Override

At the back of the INPRESS TS unit there is a small switch, this will turn off INPRESS control and run High Pressure Air Filtration unit by itself at full speed.

We do not recommend this.

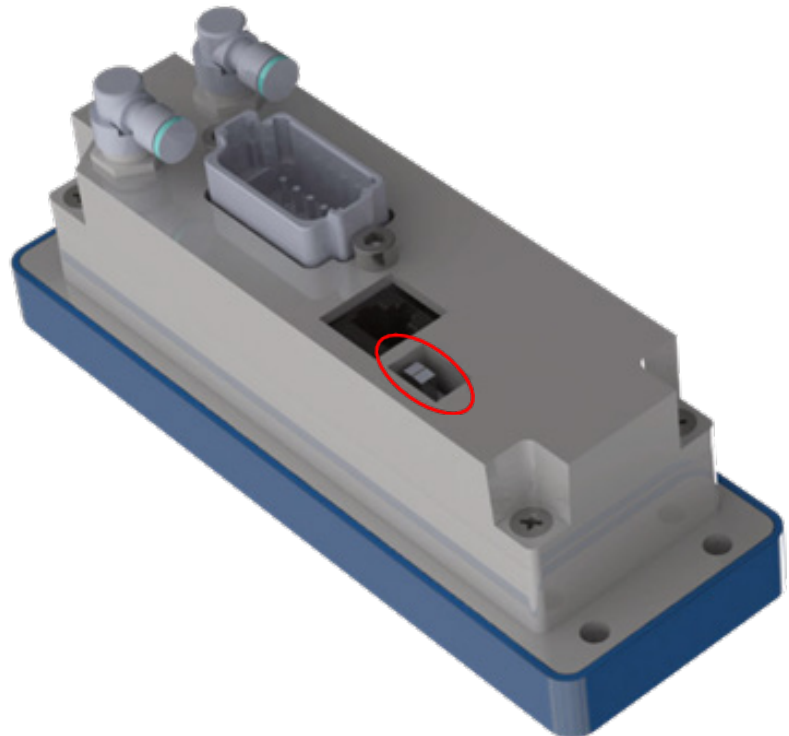



# InPress

---

## Data Logging Information

### Set Interval Minutes

Use ARROW buttons to adjust the frequency of Data recordings.

### Clear Data Log

Pressing the CLEAR DATA LOG button takes you to the PIN Entry Screen (Factory Access PIN is required). Once the PIN is entered, the Unit clears and deletes the stored data.

The screen will show a progress bar during this step, then will return to the “Factory Settings Screen” on completion.

### Download Log File

Pressing this button begins the download of the stored data to the terminal software installed on your computer. The logging intervals for the downloaded data will be based on the Set Interval.

The screen will show a progress bar during this step, then will return to the “Factory Settings Screen” on completion.

### Get Real Time Log

Pressing this button begins the output of the log data to the terminal software installed on your computer. The logging intervals for the real time data will be every second. The button will change text to “STOP REAL TIME LOG” and can be pressed to stop the feed.

### Set Up Data Retrieval

Using a serial connector on the wiring harness (or by fitting the bridging harness with serial connector), connect your computer with a serial cable.

Using terminal software similar to the freeware program TeraTerm (easily found through an internet search).

In the software set up the connection as a SERIAL Connection via one of your computer’s COM Ports, ensuring your Serial settings are as follows:

Baud Rate: 57600 Data: 8 Bit

Parity: EVEN

Stop: 2 Bit

Flow Control: NONE

### Data Logging Schedule

The BreatheSafe INPRESS TS controller is designed to start data logging as soon as it is powered up. Data samples are taken and recorded at intervals with time, date, and current pressure readings. This is additional to normal alarm logging which occurs at every alarm instance.

The unit is designed to log over 10900 instances in its internal memory. The memory is not battery dependent and can retain data for up to 10 years. Under normal operation the controller logs one sample every hour.

This time period is shortened if the BreatheSafe INPRESS TS unit experiences many alarms throughout each day.

When the data logger’s memory is full it returns to the beginning and over-writes previously recorded data in an endless loop. It is therefore very important that the data is downloaded as required to ensure that there is no loss of important information.

## Data Download - Setting Up RS232 Connection

1. Plug the RS232/USB adaptor into a free USB port on your computer.
2. Open up TeraTerm software. (TeraTerm is an open-source software tool and easily accessible via online search).
3. Use the following settings in TeraTerm: Serial and choose the correct port connection. Hint: Click on the COMxx Port with the “USB serial Port” connection from the drop-down menu.  
Example: COM 4 This connection may be different on your computer.

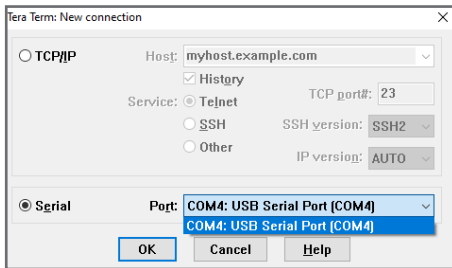

4. Click OK once the correct communication port has been identified.

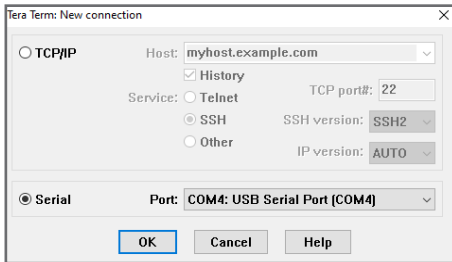

5. Go to SETUP and click on Serial Port.

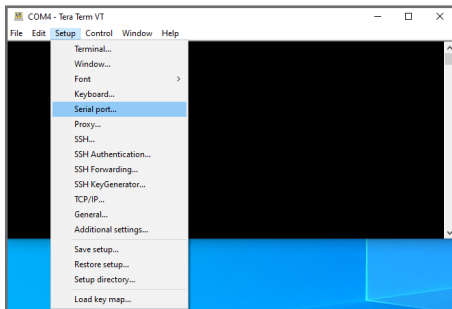

6. Change the COM ports to the following configuration: Baud Rate: 57600 Data: 8 bit Parity: EVEN Stop: 2 bit Flow Control: NONE

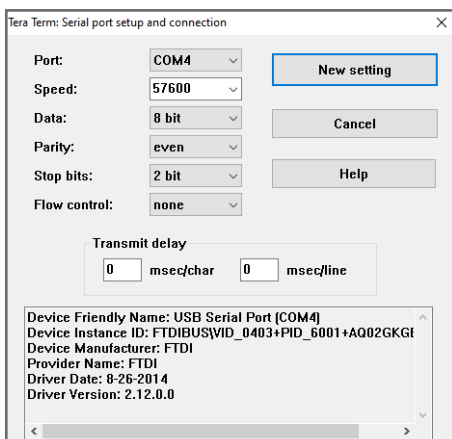

# InPress

7. If required, you may choose to save the COM port settings. Go to Settings and click save the setup.  
Hint: From the drop-down menu, click on the Save Setup.  
Name the file and save it.

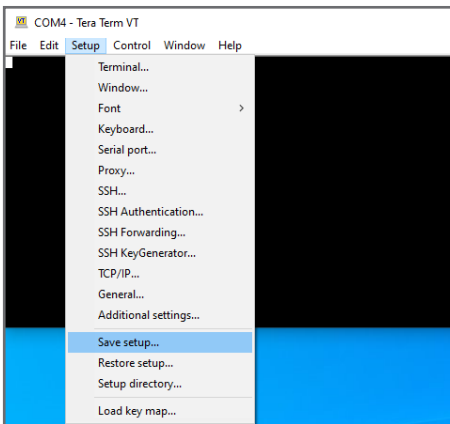

8. The next time a download is required, you may restore the setup, and the required COM PORT settings will be loaded, ready to download the data file from the 200027 unit.

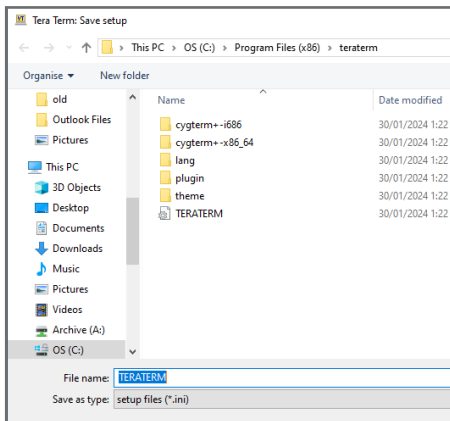

9. From the drop-down menu, click on Restore setup.

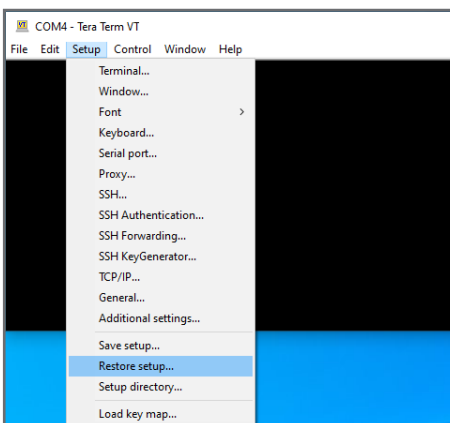

10. Choose the file name you have already saved.

# InPress

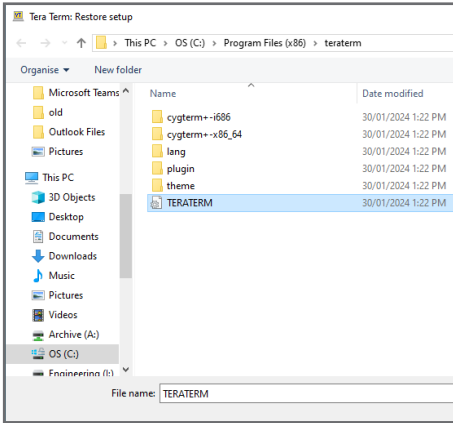

## INPRESS Controller Set Up

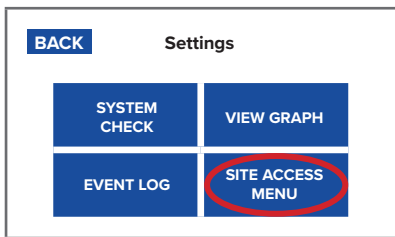

Press 'SITE ACCESS MENU'.

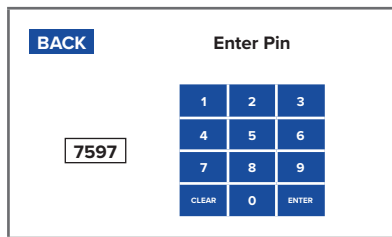

Enter the access pin '7597'.

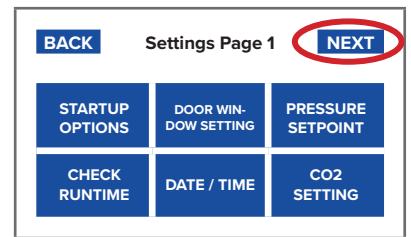

Press 'NEXT'.

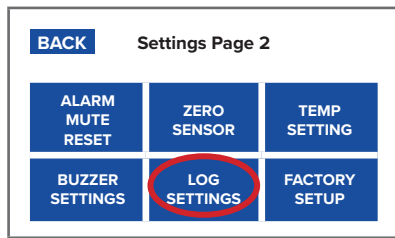

Press 'LOG SETTINGS'.

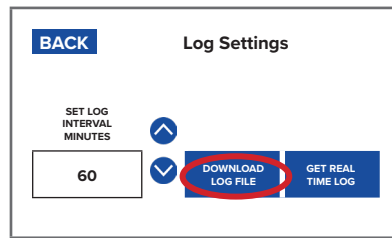

Press 'DOWNLOAD LOG FILE'.

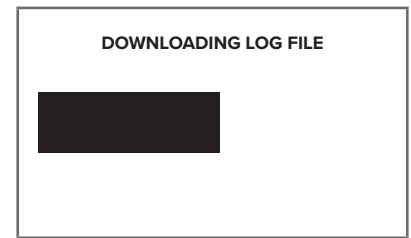

Data is now downloading from controller to terminal open on the computer (TeraTerm in this example).

11. From the drop-down menu, click on the Edit menu function.
12. Press "Select all".

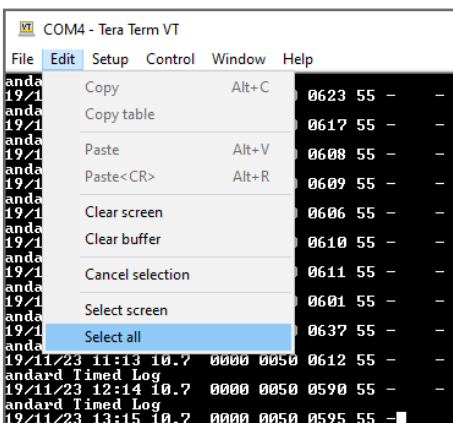

13. Select “Copy table”.

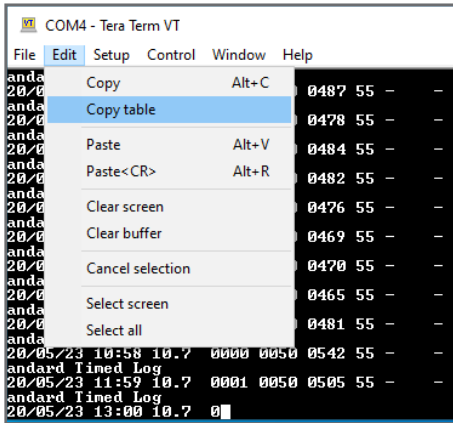

14. Open a blank excel document and click on the page. Then, right-click to paste the copied table.
15. Fields are: Date, time, motor (volts) output (e.g. 5.5 = 55%), cabin pressure (Pa), cabin pressure pre=set (Pa), CO2 sensor.

	A	B	C	D	E	F
1	DATE	TIME	MOTOR (VOLT) OUTPUT	CABIN PRESSURE PA	CABIN PRESET PA	CO2 Sensor
2	12/11/2023	16:43	2.1	50	50	600
3	12/11/2023	17:44	2.1	50	50	596
4	12/11/2023	18:46	2.1	51	50	601
5	12/11/2023	19:47	2.1	50	50	603
6	12/11/2023	20:48	2.1	50	50	595
7	12/11/2023	21:50	2.1	50	50	593
8	12/11/2023	22:51	2.1	50	50	591
9	12/11/2023	23:52	2.1	50	50	588
10	13/11/2023	0:54	2.1	51	50	595
11	13/11/2023	1:55	2.1	50	50	582
12	13/11/2023	2:56	2.1	50	50	587
13	13/11/2023	3:58	2.1	51	50	593
14	13/11/2023	4:59	2.1	50	50	598
15	13/11/2023	6:00	2.1	51	50	742
16	13/11/2023	7:02	2.1	51	50	767

### Excel Data Instructions – Unformatted

Open an Excel sheet and select the first cell A-1. Next, press and hold down the CTRL button on your keyboard and then press the letter V on the keyboard.

This procedure will paste the copied data onto that Excel sheet. Once that data has been pasted onto the Excel sheet, click on ‘DATA’ on the pull-down menu, followed by ‘Text to Columns’. Next, select ‘Delimited’ on the newly opened window and click on Next.

Only select the ‘Comma’ button in the next window and then click ‘Finish’. Then, the Excel fields will update such that each piece of data is placed in the correct columns.

The data is now ready for archiving.

### Data Logging Formats

BU No: xxxxxx (the device number unique to each unit and used for identification – format = 000000)

Time: [09:25]

Date: [25/07/12]

Pressure: 32 (Pascals) as an example.

# InPress

---

## Warranty

### Express Warranty

All BreatheSafe products carry a warranty against defects in materials or workmanship, provided the defects are not from factors outside of BreatheSafe's control (including neglect, lack of maintenance, improper installation or operation, unauthorized servicing repair, etc.). BreatheSafe will replace goods defected in material or workmanship at our Queensland factory or designated branch\*. All parts deemed as failed or faulty must be returned to BreatheSafe for evaluation unless otherwise stated in writing.

Note- Systems must be installed and commissioned as per BreatheSafe installation and commissioning instructions. Once commissioned, the online commissioning sheet must be filled in, extending the components warranty as below. In addition, the system must be serviced and maintained correctly and by trained and qualified personnel. This requisite includes BreatheSafe technicians, qualified automotive air-conditioning technicians, or qualified auto electricians.

### Warranty period – Standard

- 1 year or 10,000 hours (whichever occurs first).
- Controllers – 1 year no extended warranty option.
- Warranty Period Extension when commissioning documents are registered online within 28 days of installation
- Extended warranty\*\* only offered if commissioning maximum pressure test reaches at least 250Pa.
- Brushless motor fixed speed two years, or 10,000 hours (whichever occurs first).
- Variable speed brushless motor 15,000 hours, or 3 years\*\* (whichever occurs first).

Must be supplied with a variable speed pressure controller, data download required for 3-year warranty option. Link to online Commissioning and Extended Warranty Registration form <https://www.breathe-safe.com.au/commission/>

### What is not covered under Express Warranty?

- Failures are due to incorrect application.
- Damage resulting from neglect, misuse, lack of maintenance, improper installation, or operation, inappropriate or abnormal use, accidental or unauthorized servicing repair.
- Failures are due to parts not being sold or approved by BreatheSafe.
- Failures arising from any other cause that is not directly related to a defect in material or workmanship.

This Express Warranty is VOID if the product is altered, modified, or used in the manner it was not designed for, also including unauthorized repairs, or using maintenance and repair parts other than those supplied by BreatheSafe.

### BreatheSafe Responsibilities

If there is a defect in material or workmanship not caused by the excluded failures during the warranty period, BreatheSafe will either replace the defective goods at our Queensland factory, or designated branch. \*

Alternatively, BreatheSafe may elect to provide new replacement parts, BreatheSafe approved repair parts or assembled components needed to repair the defect. BreatheSafe reserves the right to provide a refund of the purchase price in lieu of replacement or repair at BreatheSafe's discretion. The replacement or repaired product will be sent to you freight prepaid by the customer or made available for pick-up on site.

### Users Responsibilities

The customer should ensure that the system is maintained according to BreatheSafe service requirements and only authorized parts must be used to service and maintain BreatheSafe systems. In the event of a suspected warranty claim, BreatheSafe should be contacted in the first instance to arrange the repair or to assist with diagnosis. Claims should be made within one week of the repair.

After contacting BreatheSafe, you may be required to deliver or send the parts to BreatheSafe's Queensland factory or designated branch. \* Link to online Warranty claim form <https://www.breathe-safe.com.au/warranty/>

### Exclusion and Limitations on Damages and Remedies

This warranty is provided in lieu of all other warranties, written or oral, whether expressed by affirmation, promise, description, drawing, model, or sample. To the extent allowed by law, all warranties other than this warranty, whether express or implied, including implied warranties of fitness for a particular purpose, are disclaimed. The maximum liability of BreatheSafe under this warranty shall not exceed the original purchase price of the product. Interference with the equipment by or abuse, or by operating the equipment at ambient temperatures or with electrical power characteristics outside the ranges indicated in our specification shall be excluded from this warranty, as shall consequential damages.

Excluded from any express warranty are costs incurred in relation to service outside our factory our designated service branch, including traveling time, waiting time, transport costs, mechanical and overtime payments required. As per Australian Consumer Law: You are entitled to choose a refund or replacement for major failures with goods. If a failure with the goods or service does not amount to a major failure, you are entitled to have the failure rectified in a reasonable time. If this is not done, you are entitled to a refund for the goods and to cancel the contract for the service and obtain a refund of any unused portion. You are also entitled to be compensated for any other reasonably foreseeable loss or damage from a failure in the goods or service.

\*This express warranty gives you specific legal rights, and you may also have other rights that vary from country to country.

