

Kit Part Number: 700388

Breathe Safe

Part of **Aire Safe**

Parts and Service Manual

KOMATSU

WA900-3EO / WD900-3 WHEEL LOADER

HEPA H14 Variable Speed Pressuriser | INPRESS TS Cabin Display with CO2 Sensor | HEPA Return Air Filters | [Air Conditioning System](#)



+61 7 3276 7833



www.breathe-safe.com.au



sales@breathe-safe.com



62 Mica Street, Carole Park, 4300, QLD

Controlled Document: M0045

Issue Date: 18/07/23

Revision: 2

INSTALLATION

CONTENTS

- INSTALLATION 1
- SAFETY 2
- CRITICAL PARTS & MAINTENANCE SCHEDULE 3
- PRESSURISER 4
- INPRESS TL TS OVERVIEW 5
- CABIN SEALING TEST 6
- PARTS LIST 7-8
- TECHNICAL DETAILS INPRESS TS 9-10
- OPERATING INSTRUCTIONS AIR 11-22
- SPECIFICATIONS PRESSURISER 23
- SPECIFICATIONS AIR CONDITIONING 24
- WIRING AIR CONDITIONING 25-28
- COMMISSIONING 29-34
- FAULT DIAGNOSIS 35-42
- SMOKE EMITTER CABIN TEST 43
- COMMISSIONING PRESSURISER 44
- TROUBLESHOOTING GUIDE 45
- USER SETTINGS INSTRUCTIONS 46-51
- DATA DOWNLOAD 52-55
- WARRANTY 56

INSTALLATION OVERVIEW

Manufacturer	KOMATSU
Type	Wheel Loader
Model	WA900-3EO/ WD900-3
Cabin Pressure Max	>250 Pascals
Set Auto Cabin Pressure	50 Pascals / 20 Pascals



HEPA H14 Variable Speed Pressuriser



INPRESS TS Cabin Display with Data Recorder

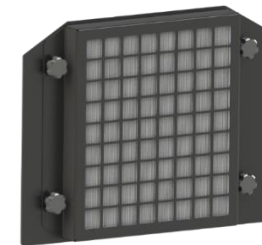

HEPA Return Air Filter

SAFETY

WARNING

THE PRESSURISATION SYSTEM DESCRIBED IN THIS MANUAL HAS THE FOLLOWING AREAS WHICH MAY BE DANGEROUS IF NOT TREATED WITH GREAT CARE.

QUALIFIED STAFF MUST WEAR THE CORRECT PERSONAL PROTECTIVE EQUIPMENT WHEN CLEANING AND SERVICING THIS UNIT DUE TO DUST AND FIBRES WHICH MAY BE CAUGHT BY THE STAGES OF AIR FILTRATION DURING NORMAL UNIT OPERATION.

THE ELECTRICAL POWER SYSTEM IS SUPPLIED BY 12V DC OR 24V DC AND NO WORK SHOULD BE CARRIED OUT ON THE PRESSURISER SYSTEM WITHOUT THE CORRECT SAFE WORK PROCEDURES AND ELECTRICAL SAFETY MEASURES BEING TAKEN, AND ALL RELEVANT CIRCUIT BREAKER OPENED TO ISOLATE THE CIRCUIT.

THE AIR FILTRATION SYSTEM MAY HAVE SEVERAL TYPES OF HIGH-SPEED ROTATING EQUIPMENT INSTALLED WITH VERY SHARP EDGES. ENSURE ALL SAFETY GUARD ARE IN PLACE WHILE THE SYSTEM IS RUNNING.

Please be aware that HEPA filters cannot be cleaned and must be replaced at the end of their lifecycle or if filter media has been damaged.



Hard Hat



Eye Protection



Dust Mask



Ear Protection



Protective Clothing

Particulate Behaviour

This is the length of time it takes for a particle to drop from a height of 1.5m in **STILL** air.

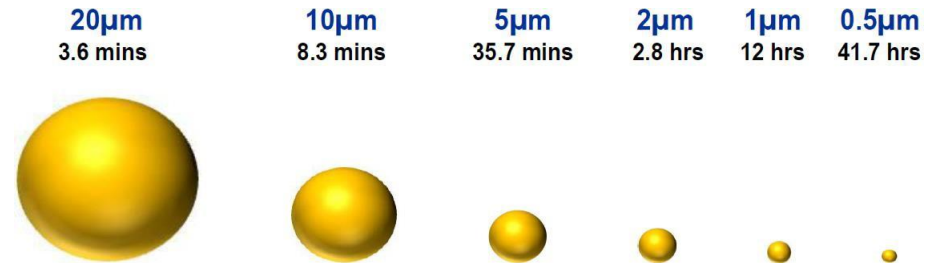

Warehouses and workshops do not have still air, so hazardous airborne particulates may remain in air for longer, increasing chance for workers to breathe in dust. Ensure PPE is worn when installing this system.



CRITICAL PARTS & MAINTENANCE SCHEDULE

Maintenance Schedule

The following tables show our suggested maintenance schedule for all units. Please note that site conditions may alter this. Excludes high corrosion environments.

Data download is required to claim the 3-year warranty on Brushless Blower Motor.

Inspect every 500 HOURS and replace when filter is full*

Component / System	Action Required
Turbo Pre-cleaner	Check operation of the Turbo Pre-Cleaner.
Pressuriser Blower	Ensure blower is operational.
HEPA Primary Filter p/n: 500000	Inspect filter capacity indicator. Replace HEPA filter when 80% or greater. Vacuum out housing before replacing the filter elements.
HEPA Return Air Filter P/N: 500039	Vacuum inside cabin floor before replacing filter.
Filter Frame Assembly, Mounts, Seals and Filter Housing	Check door seals, all bolts, screws, and all mounts are secure. Check the filter canister & ensure it is correctly fitted. Check latches are operational and in good order. Replace / Re-tension fixtures and fittings required.

15,000 Hours / 36 months*

Component / System	Action Required
500 Hour Inspection	All 500-hour inspection actions.
Pressuriser's Blower 200002	Replace BRUSHLESS Pressuriser blower.

Critical Parts				
Item	Part Number	Qty.	Description	Service Interval
1	500000	1	Fresh Air HEPA H14 Filter (Tested as per EN1822)	1000* Hours (>80% fan capacity)
2	500039	1	HEPA Return Air Filter	500* Hours
3	200002	1	Brushless Blower Motor – 24V	15,000 Hours
4	200027	1	BreatheSafe Digital Display – Data Recorder (INPRESS TS)	

*Filter service hours are subject to cab sealing efficiency, site conditions and correct system use.

Suggested Schedule Servicing*

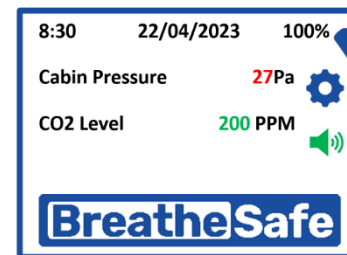

Fan Capacity Indicator

The filter is serviceable if the motor capacity is between 10% & 80%. We recommend that the filter is changed if the capacity is over 80%.

*Site dependent

OPERATOR GUIDE

OPERATORS CHECKLIST

PRE-START

1. Visually inspect the BreatheSafe system for any damage.
2. Visually inspect the cabin for any damage to doors, windows, seals.
3. Please remove dust & debris from shoes and clothes before entering the cabin.
4. Ensure door(s) and windows are closed correctly.
5. Start engine and turn HVAC on to speed 2 (medium speed).
6. After fixed speed delay, the BreatheSafe display will show 50 Pascals or pre-set value.

The system is working correctly when the pascal value is green.
>> There is no further action required <<

NORMAL OPERATING CONDITION

Cab Air Conditioning

BreatheSafe recommends OEM air conditioning fan is set at mid speed or greater to circulate air around the breathing zone and minimise CO₂.

Acceptable operating range for BreatheSafe fan 10-80%. >80% recommend maintenance.

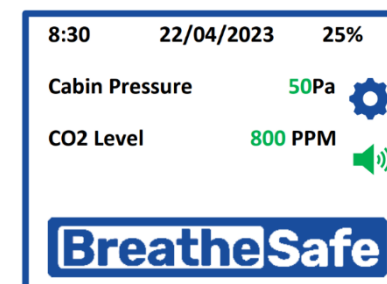

ALERTS

Fixed Fan Start Delay

- Allows the operator to carry out pre-start checks – limiting at 30% fan speed, press the red text to disable.

CO₂ Level Alert (if equipped)

- Ensure air conditioning fan is set at mid speed or greater to circulate air and minimise CO₂.

Low Pressure Alarm

- Cabin is not maintaining positive pressure – check doors and windows are closed correctly.
- Refer to maintenance department to check filters and cabin sealing. Ensure filters are serviceable.

Check Filter

- Reminder to inspect or replace filter. Service hour meter requires re-set.
- Refer to maintenance department.



Specifications High-Capacity HEPA Pressuriser

Blower	: Brushless Blower P/N 200002.
Protection	: Locked Rotor Protection (Sub Zero Environments) Under Voltage, Under/Over Current & Over Temperature.
Voltage	: 24VDC.
Current Draw	: 11 amps (peak). *Note: Motor has slow start to stop excessive in-rush current.
Air Flow	: Up to 30-300 m ³ /h or 50-215 CFM.
Pre-cleaner	: Integrated VLR (Very Low Restriction). Turbo Pre-Cleaner.
Filter Element	: BreatheSafe HEPA Primary Filter (H14=99.99% MPPS) TESTED AS PER EN1822 – P/N 500000.
Plugs & Fittings	: Mining Spec. Deutsch electrical plugs as standard.
Construction	: High strength composite construction.
Serviceability	: Easy access HEPA filter with twist-lock (TL) dust cap single assembly.
Mounting	: Heavy Duty adjustable mounting brackets.
Design	: Fully designed in SolidWorks 3D CAD & Ansys Engineering Simulation Software.
FEA Testing	: Critical components FEA (Finite Element Analyst) tested in Solid Works Simulation.
CFD Testing	: CFD (Computational Fluid Dynamics) simulations in Flow Works to ensure optimum air flow through the system.

SPECIFICATIONS HIGH-CAPACITY HEPA PRESSURISER

List of Abbreviations	
DH	Dual HEPA
DHPR	Dual HEPA Powered Recirculation
DHAC	Dual HEPA Activated Carbon
DHACPR	Dual HEPA Activated Carbon Powered Recirculation
CPM	Cabin Pressure Monitor
CPU	Central Processing Unit
DB	Decibel Sensor
DPM	Diesel Particulate Matter
GAS	Gas Sensor
HEPA	High-Efficiency Particulate Air Filter
HPAFU	High Pressure Air Filtration Unit
HRAF	HEPA Return Air Filter
HVAC	Heating Ventilation and Air Conditioning
MAF	Mass Air Flow
OEM	Original Equipment Manufacturer
PM	Particulate Mass
RH	Relative Humidity
TEMP	Temperature
TS	Touch screen
UI	User Interface
VMS	Vehicle Monitoring System
VS	Vibration Sensor
OGSP	OnGuard Sensor Pod
CO2s	CO2 Sensor INPRESS TS

Item No.	Qty.	Description	Part No.
1	1	Pre-cleaner Hood & Rotor Assy	200004
2	4	Pre-cleaner Injector Ring	200005
3	1	TL Fan Blade (inc. in #7)	200006
4	1	TL Nose Cone / Pre-cleaner	200007
5	1	TL Motor Housing	200008
6	1	TL Filter Housing	200009
7	1	24v DC Brushless VSD Motor & TL Fan Blade	200002
8	1	O Ring Seal Kit 2 Parts	200010
9	1	Included in 8	200011
10	1	Wiring Sleeve	200012
11	1	HEPA H14 Filter	500000
12	3	M6 Nyloc Nut	300218 (M6NYL)
13	3	M6 x 55mm Hex Bolt	300982 (M655B)
14	4	M8 x 190 Hex Bolt	301136 (M8190B)
15	8	M8 x 22mm O/D HD Washer	300230 (M8222HTW)
16	4	M8 Nyloc Nut	300249 (M8NYL)
17	5	M4 x 75mm Pan Head Phillips Screw	300162 (M475PBH)

PARTS LIST – TL4 24V DC PRESSURISER UNIT

PRESSURISER ASSEMBLY No: **200000**

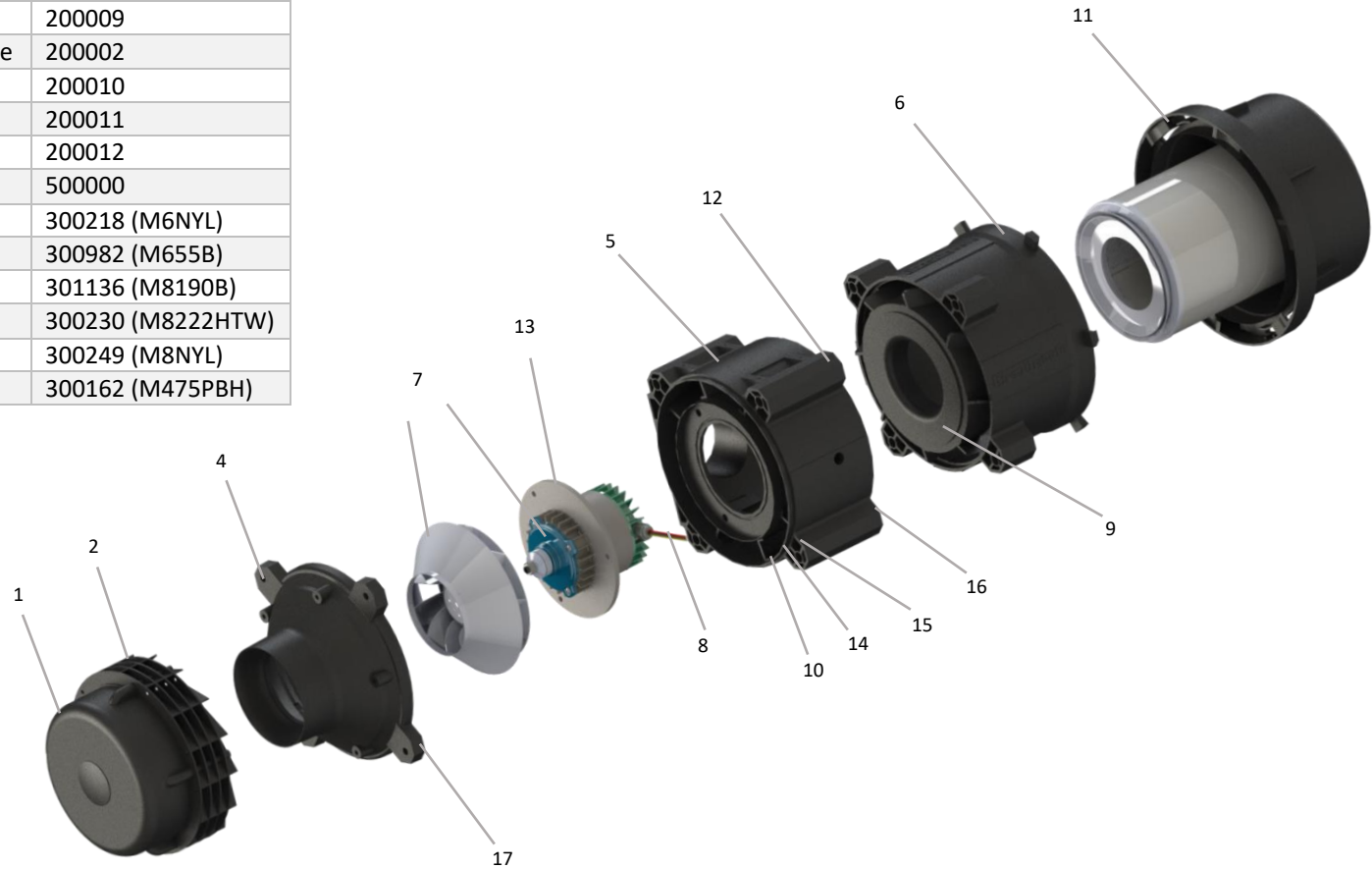

Operator Guide

INPRESS TL TS OVERVIEW

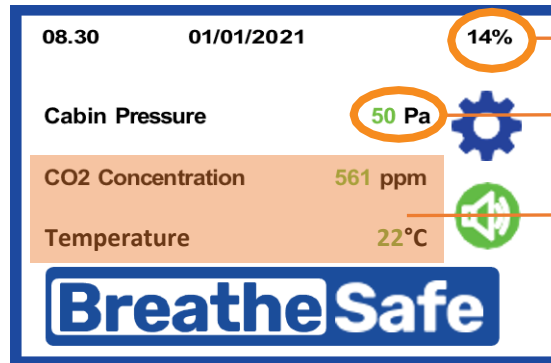

Motor Capacity

Cabin Pressure

Options:

- CO2 Sensor (ISO 23875)
- Temperature Sensor

The BreatheSafe system fitted is fully automatic. Always keep door and windows closed even when not in service to prevent airborne dust entering the cabin – always during maintenance. A 10 minute “Pre-Start” program setting will ensure the pressuriser speed remains at 30% motor capacity (user resettable 1-10 min or disabled).

During the walk around / Pre-start:	Visually inspect the cabin for any damage to doors, windows, seals.	
Before and after entering the cabin:	1	Please remove debris from shoes and clothes before entering the cabin.
	2	Ensure doors are fully closed, and windows are fully shut.
	3	[Start the engine] & turn HVAC on the speed 2 (Medium speed).
	4	The BreatheSafe display shows 50 Pascals or above.
>> There is no further action required << Please clean the cabin regularly – Use a HEPA-type vacuum and do not use a brush or compressed air.		
Troubleshooting – if the display indicated is below 50 pascals (customer specified) or low-pressure alarm is activated, please check the following:	1	Double-check door(s) are fully closed
	2	Double-check window(s) are fully closed
	3	Double-check for any signs of damage: door, windows, seals, or missing panels.
If the display is below 50 pascals (customer specified), please check the following:	Monitor the % (volts) output to BreatheSafe cabin pressure display (i.e., 100% means the fresh air filter is completely dust loaded or a significant cabin pressure leak that the pressuriser cannot overcome).	
Please note: Positive pressure above 20 pascals (ISO 23875 minimum) is adequate until the next available service.		

CABIN SEALING TEST PROCEDURE

Cabin Sealing Efficiency Test Procedure

1	Start Engine – Pressuriser System is ON
2	Ensure all windows & door(s) are CLOSED correctly (no cabin pressure leaks) NOTE: for a new cabin with effective seals, you may need to open a window slightly before closing the door to bleed the static cabin air pressure outwards. Once door is fully closed then close windows to begin testing.
3	Enter the Settings menu via the touch screen button.
4	Select and press the System Check button to go to System Test – Max Fan.
5	Record / photograph the maximum cabin pressure achieved.

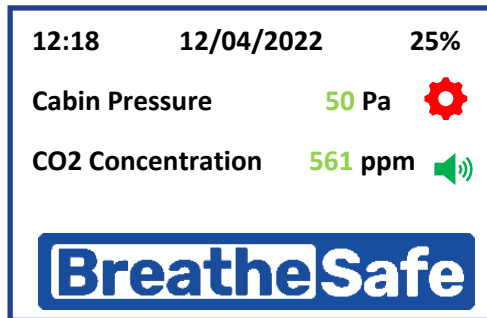

Press Settings.

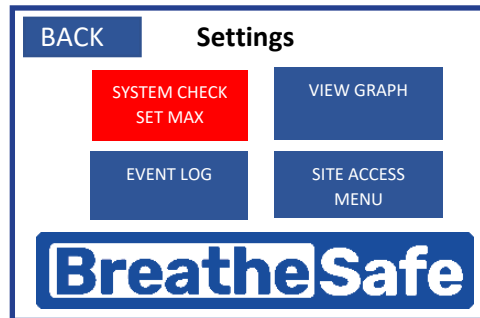

Press "System Check – Set Max" box.

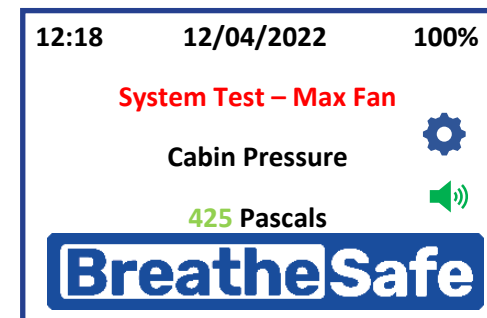

Record / Photograph the cabin pressure result (Max Fan Speed).

PARTS LIST

Item No.	Part No	Rev	Description	Qty	Group
1	100402H01	0	Evaporator Module	1	Module
2	100402C01	0	Condenser Module	1	Module
3	08511	4	(WA900) TL4 Side Mount Assy	1	Module
4	200000	[*]	HPAFU 24VDC VSD TL4	1	Stock Item
5	250049	[*]	TL Side Mount WC Cover	1	Stock Item
6	200036	[*]	Gasket Seal 76mm Spigot	1	Stock Item

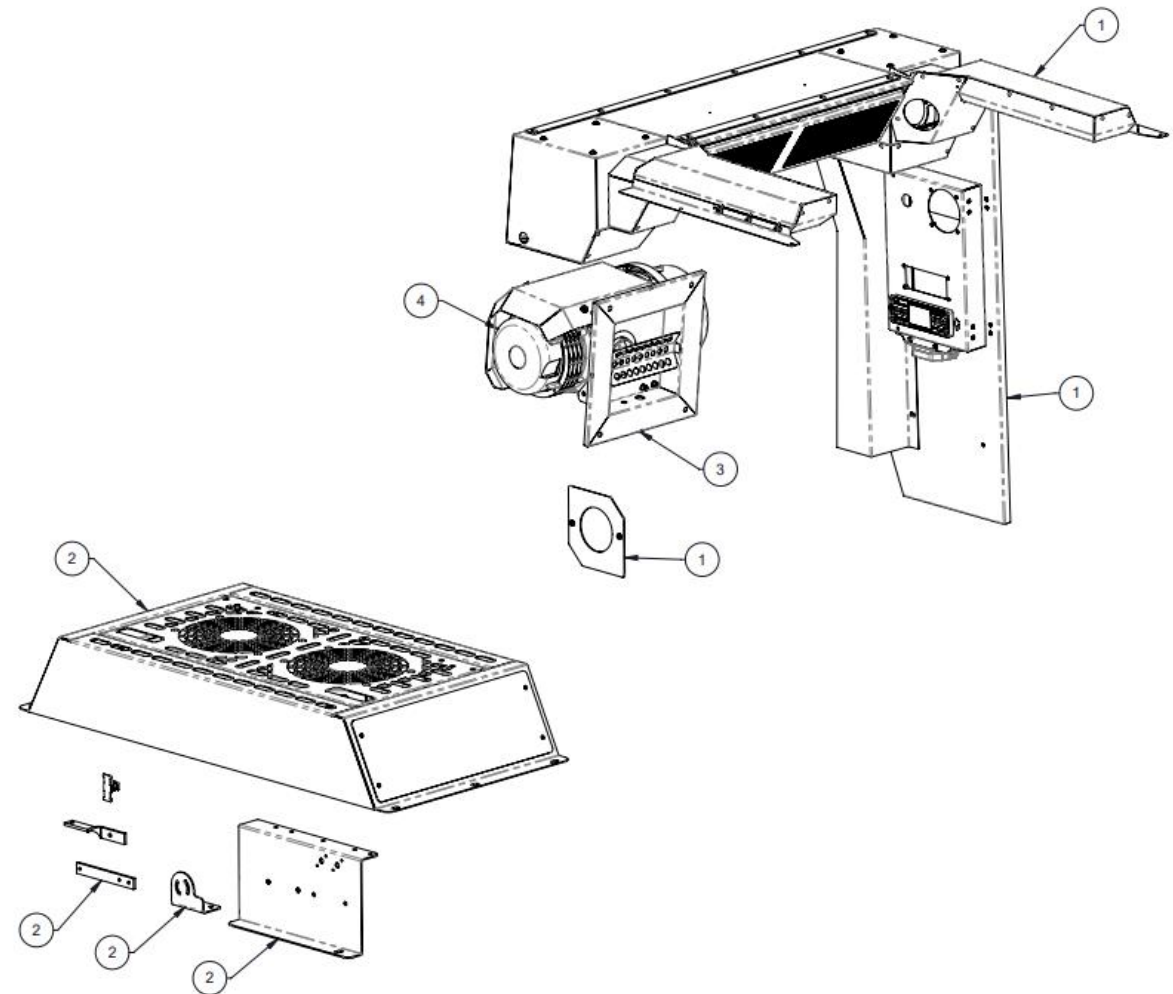
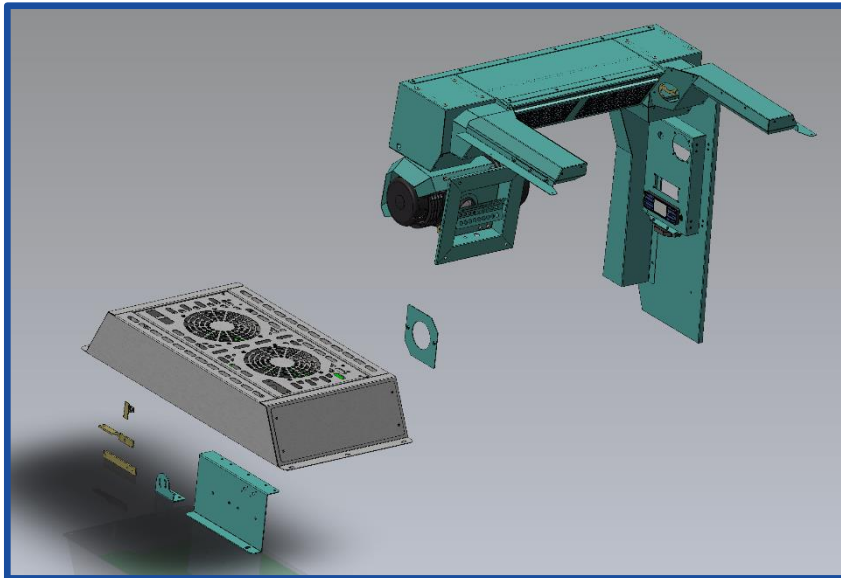

PARTS LIST

Item No.	Part No	Rev	Description	Qty	Group
1	300275	-	Condenser Coil	1	-
2	200334	-	Condenser Fans	2	-

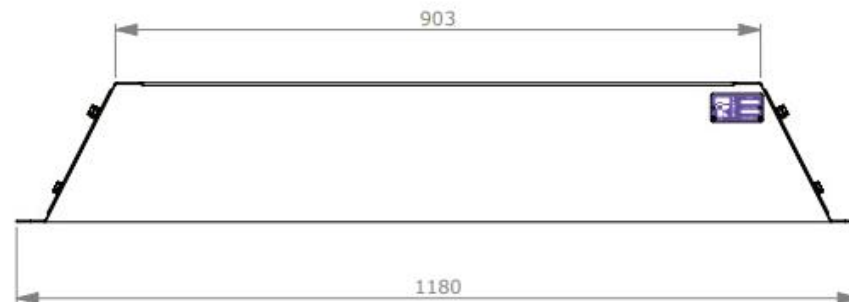
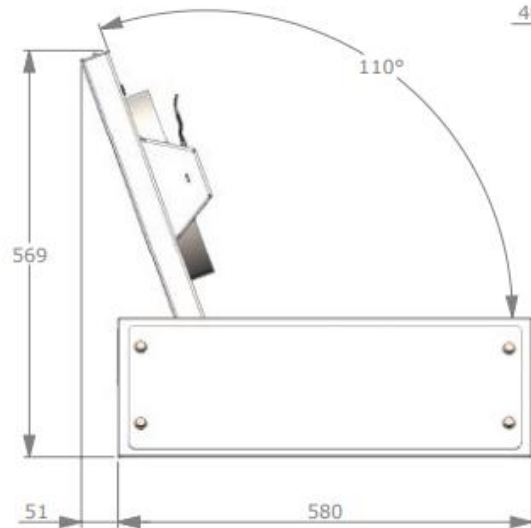
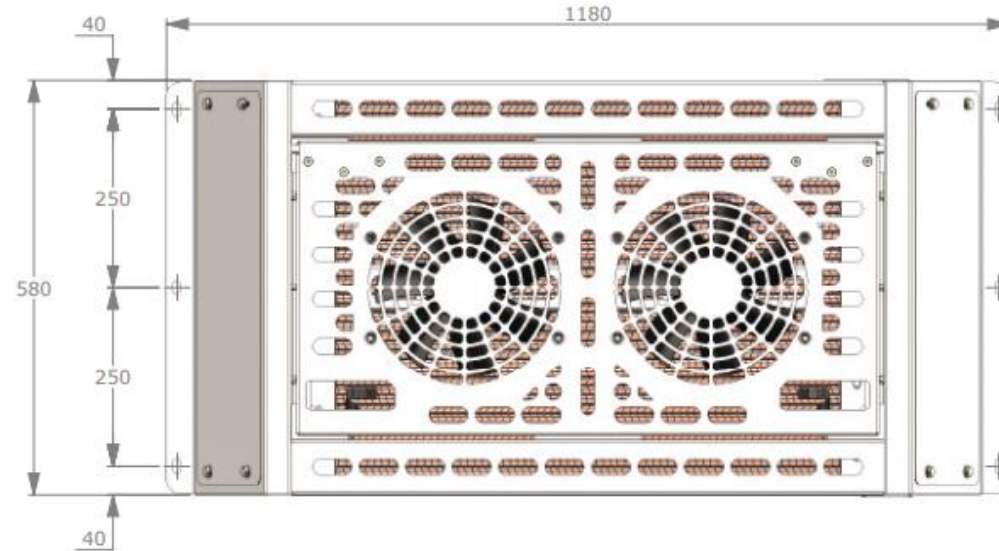

TECHNICAL DETAILS

Display Key Features

- Digital cabin pressure monitoring system
- Automatic cabin pressure control
- Intelligent fan speed output
- Data logger
- Alarm for low-pressure (RS20)
- Light sensor for automatic dimming of the screen

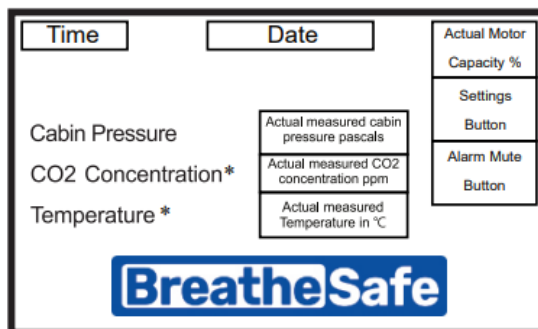
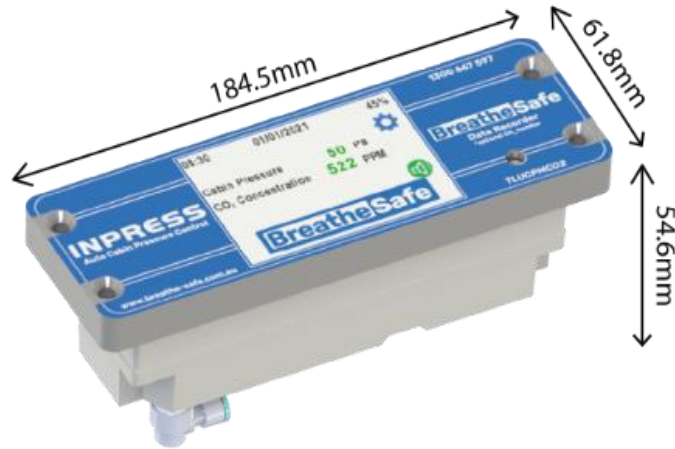

MAIN SCREEN

Options* when fitted

CO2 Sensor

- CO2 Sensor Type is NDIR (Non-Dispersive Infrared)
- Sample Rate is every 2 seconds
- 12-30V DC Operating Voltage
- Automatic Altitude Compensation
- Alarm Set points are adjustable
- No setup required



Connections: 200027



Item	Destination
1	PIPE A – AMBIENT PRESSURE – OUTSIDE
2	PIPE B – POSITIVE PRESSURE – INSIDE
3	RJ45 CONNECTOR – CO2 SENSOR
4	OVERRIDE TOGGLE SW = MAX SPEED

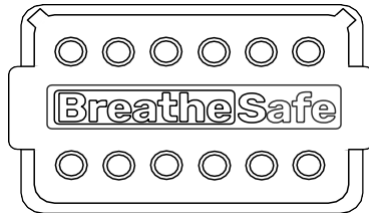

Item	Destination
1	12/24 VOLT POSITIVE SUPPLY
2	CAN H OPTION
3	CAN L OPTION
4	SERIAL TRANSMIT RS232
5	MOTOR CONTROL VOLTS OUT
6	ALARM + OUTPUT
7	TEMP SENSOR
8	NO CONNECTION
9	SERIAL RECEIVE RS232
10	DOOR INPUT (+)
11	WINDOW INPUT (+)
12	0V NEGATIVE GROUND

TECHNICAL DETAILS

Wiring Diagram

INPRESS User Interface (UI)

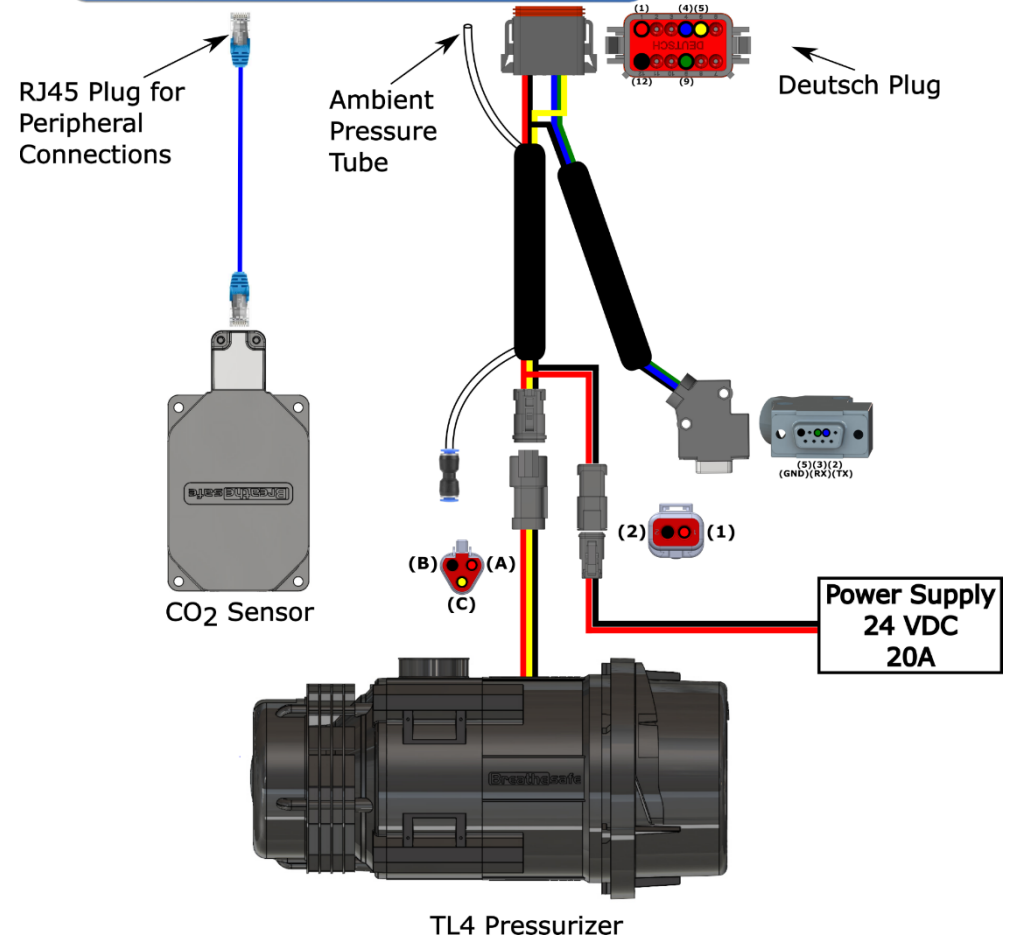
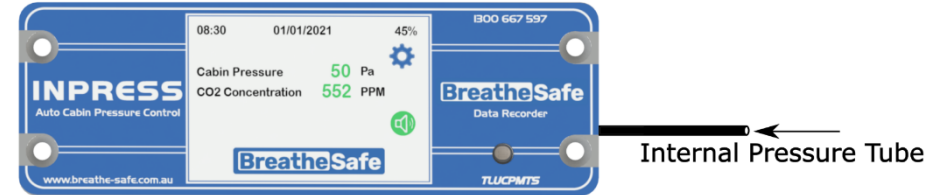

BreatheSafe Air Conditioning Control – 301478

1. Controller Appearance

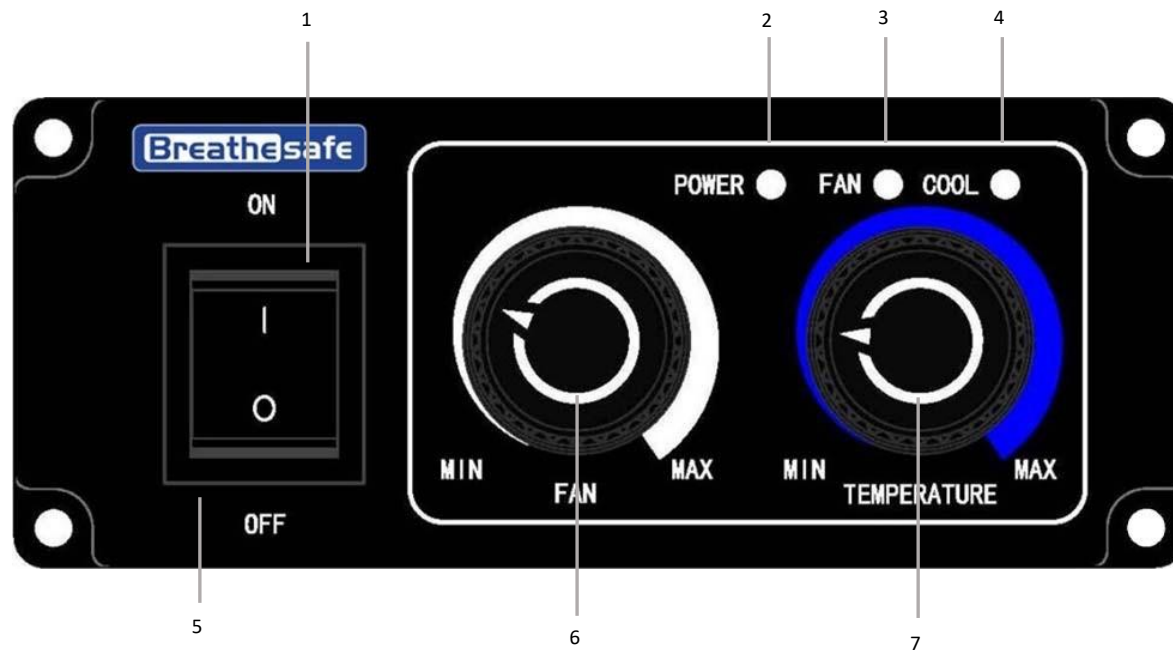

ITEM	DESCRIPTION
1	Power Switch
2	Power Indicator
3	Fan Motor Indicator
4	Cooling Indicator
5	PET Cover
6	Fan Speed Regulation
7	Temp Setting Regulation

IMPORTANT: The air conditioning system must be run for a minimum of five minutes each week regardless of the season to lubricate the system and prevent damage to the seals.

AIR CONDITIONING SYSTEM

Air Conditioning System

CONSTRUCTION

Cases are fabricated from heavy gauge zinc plated steel. 100% Powder coat finish as standard.

All wetted surfaces are lined with a combination sound deadening and condensate preventative compound.



AUTOMATIC CONTROLS

A combination HP/LP switch provides for safety cut-out and is connected in series with a defrost type thermostat in the compressor clutch circuit.



FANS & BLOWERS

Our fan and blowers are totally enclosed and come equipped with fully sealed shafts, heavy duty bearings and non-replaceable brushes.



COILS

Heat exchangers are of heavy gauge copper or aluminium tube and aluminium fin construction. They have been sized and designed to maintain reasonable pressures at a wide range of conditions and loads.

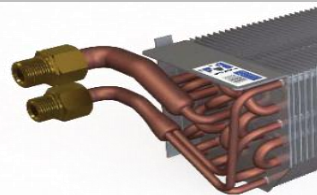

ELECTRICAL CONTROLS

The universal electronic thermostat has been selected for its reliability and functionality.

It has been pre-programmed to provide optimum temperature control for the operator's comfort.

The return air probe is located in the return air. The return air temperature is adjustable via the digital control panel and has a nominal set-point range between 15°C to 32°C.

Incorporated into the electrical circuit are four circuit breakers which protect all fan motors, compressor, and various other electronic components and wiring. In circumstances of tripping, they can be easily accessed and reset through return air.

PERFORMANCE SPECIFICATIONS

Cooling Capacity	8.0 kW
Evaporator Air on Temperature	29°C DB / 19°C WB
Suction Temperature	-2°C
Ambient Temperature	46°C
Refrigerant	R134a
Total Refrigerant Charge	2.8kg +/- 100g

THERMOSTAT

The electronic thermostat controls return air temperature and coil temperature.

Power Supply	24V DC
Selectable Return Air Temperature	18°C - 28°C
Dead Band	0.5°C (Either side of set point)
De-Ice Cut Out Temperature	2°C
De-Ice Cut In Temperature	8°C

AIR CONDITIONING SYSTEM

Principals of Air Conditioning

The components, which combine to make up the air conditioning system, are in four different circuits as under:

- Air Circuit
- Refrigeration Circuit
- Heating Circuit
- Electrical Circuit

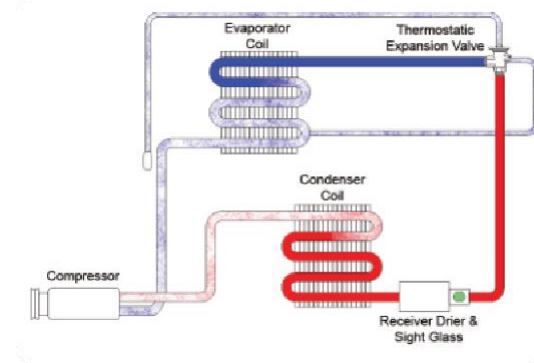

AIR CIRCUIT

The evaporator section has a basic air recirculation circuit provided by two forward curved fans in parallel. These blow air through the evaporator and deliver the conditioned air into the cab. Average cab temperature is controlled by a thermostat, the capillary of which senses the temperature of the coil. A second circuit is created by the addition of a filter / pressuriser. If fitted this consists of two stages of filtering, followed by a single stage pressurising fan with the filtered fresh air being mixed with cab return air before passing over the heat exchange coils. Depending on the model of condenser, the condenser air is provided by either one axial (propeller) flow fan and drawn through the bottom of the condenser coil and discharged through the top of the condenser. Or the condenser air is provided by three axial fans and drawn through the top of the condenser and discharged over the condenser coil.

REFRIGERATION CIRCUIT

To illustrate the change of state of the refrigerant as it travels through the system, the descriptions of the refrigeration components have been listed in the order which coincides with refrigerant flow.

6. Condenser Coil

Condensing of the refrigerant is the change of state of the refrigerant from a vapour to a liquid. The condenser receives the high-pressure, high temperature refrigerant vapour from the compressor and condenses it to a high temperature liquid. The liquid refrigerant then flows to the receiver drier.

7. Receiver Drier

The receiver drier utilised in these units is of fully welded construction, fitted with an integral sight glass. The receiver drier serves as a reservoir for the storage of high-pressure liquid produced in the condenser. It also functions as a filter/drier by means of a dehydrating agent combined with filtration system to trap minute particles of moisture and foreign material which may have entered the refrigeration system.

8. Thermostatic Expansion Valve

The expansion valve is located on the evaporator inlet line and provides the functions of throttling and controlling the flow of liquid refrigerant to the evaporator coil. This refrigerant flow is restricted creating a pressure drop across the valve. Thus, the refrigerant that enters the valve as a hot high-pressure liquid exits it as a cold low-pressure liquid. The flow rate will vary according to the heat load, sensed by the diaphragm capillary, and the suction pressure at the evaporator.

1. Evaporator Coil

The evaporator coil is constructed from copper tubing, through which passes the R134a refrigerant, and aluminium fins for optimum heat transfer. The refrigerant evaporates as it passes through the copper tubes due to heat, which it absorbs from the hot air flowing over and around the fins and tubes. This absorption of heat reduces the temperature of the air passing through the coil, thus cooling the cab. The refrigerant boils off becoming a low-pressure gas.

2. Compressor

The function of the compressor is to compress the refrigerant in the system, thus concentrating the resultant rise in temperature. At the compressor, the low-pressure gas is changed to a high pressure, high temperature gas. This pressure build-up is accomplished by having a restriction in the high-pressure side of the system. This restriction occurs at the metered orifice in the T.X. valve. The compressor is normally belt driven from the engine PTO. An electromagnetic clutch is typically used to provide a means of stopping the compressor from pumping when refrigerant flow is not desired or when a malfunction develops within the system.

3. Compressor Service Valves

Two service valves are located on the top of the compressor cylinder head. The valves enable the connecting of system test gauges and also to isolate the compressor from the rest of the system to facilitate compressor replacement. The high (discharge) side service valve is quickly identified by the smaller discharge hose routed to the condenser, while the low (suction) side has a larger hose coming from the evaporator. The valve is normally back-seated, closing off the gauge port allowing normal system operation. The valve should be in this position before disconnecting any service equipment. The valve should be in the mid position when the system is operating, and any service equipment is connected. Loss of refrigerant gas will occur if the valve is opened to this position without first connecting the service equipment. The front-seated position of the valve shuts off flow to both the gauge port and compressor. This position is used when isolation of the compressor from the rest of the system is desired. Operation of the compressor with the valve in this position will result in severe compressor damage due to excessive build-up.

4. Heating Circuit

The heater coil (if available) is supplied with hot water from the main engine cooling system. Control is via a manually operated valve in the supply line or via the electronic thermostat (if available), which can be operated whilst in cooling mode to provide some humidity control and rapid demisting.

5. Electrical Circuit

Battery power is circuited through a circuit breaker to the main four-position switch or electronic thermostat (if available) which provides for control of the three-speed recirculating (supply) air fan. The compressor clutch is in series with the High Pressure / Low Pressure safety switch and thermostat protecting the system. A circuit breaker operates through a relay to supply full voltage to the condenser fan motors.

OPERATING INSTRUCTIONS

Operating Instructions

2. Plugging & Unplugging

IMPORTANT: The electrical power system is supplied by 24v DC. No work should be carried out on the system without the correct electrical safety measures being taken and all relevant circuit breakers opened to isolate the circuit.

Make sure the power is off while plugging and unplugging the controller.

To remove the controller, please press in the middle of the panel and with two screwdrivers, gently pry the controller free. Once started it will eject automatically.

To install the controller again, please push it firmly from the right hole and ensure the controller securely fastening.

Make sure the power is off while plugging and unplugging the controller.

3. Wiring

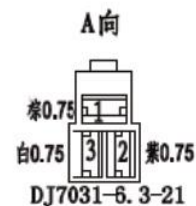

Connector A

1. Brown 0.75: GND
2. Purple 0.75: Control wire of compressor
3. White 0.75: Control wire of fan speed regulation



Connector B

1. Yellow/ green 0.75: Interior temp sensor
2. Brown 0.75: GND
3. Green 0.75: Defrost temp sensor
4. Brown 0.75: GND

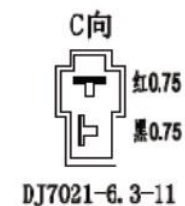

Connector C

1. Red 0.75: +24V ACC power
2. Black 0.75: GND

4. Technical Specification

Rated Voltage	: DC24 (DC19V~ DC32V) : - 30°C / +80°C : 5% 95% RH non-condensing
Basic Input	: (1) (25°C, Rb=5K, B=3274) Interior temp. sensor (at 25°C, Rb=5K, B=3274) : (2) (25°C, Rb=5K, B=3274) Defrost temp. sensor (at 25°C, Rb=5K, B=3274) : (3) ACC Battery
Basic Output	: (1) 1.6 ~ 10V Fan speed signal 1.6 ~ 10V : (2) 1A Cooling (Max 1A)

Notes:

These outputs are effective at high level (positive).

Setting temp. range	: 15 ~ 32°C, ±1°C
Cooling Mode	: 15 ~ 32°C, precision ±1°C
Protection	: IP54
EMC Level	: ISO7637-2
Weight	: 255g

OPERATING INSTRUCTIONS

5. Operation Instruction

Air Volume Regulation



Turning the knob to MIN, decreases the air volume to 15%. The voltage output is 1.6V and the fan motor runs at 600RPM.

Turning the knob to MAX, increases the air volume to 100%. The voltage output is 10V and the fan motor runs at full speed.

Temperature Setting



Turn the Temperature Knob to set the temperature value in the range of 15~32°C.

Power Switch

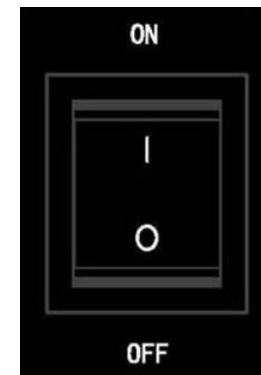

Pressing the switch to "ON", turns the controller and system on.

Pressing the switch to "OFF", turns the controller and system off.

IMPORTANT: The air conditioning system must be run for a minimum of five minutes each week regardless of the season to lubricate the system and prevent damage to the seals.

OPERATING INSTRUCTIONS

6. Start-up Procedure

With the engine running, press the Power Switch (1) to the “ON” position starts the Air Conditioning System.

Adjust the Temperature (7) and Fan (8) control knobs to set the temperature and air flow as required.

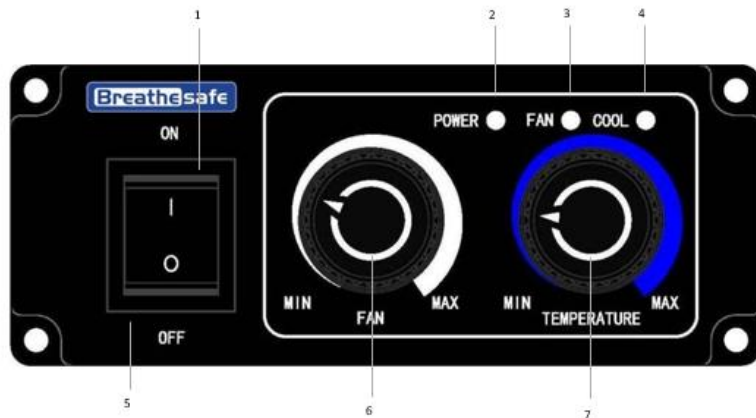

7. Cooling Function

The Controller regulates the cabin temperature as follows:

- If the interior temperature \leq setting temp 2°C , the compressor is turned off.
- If the interior temperature \geq setting temp 2°C , the compressor is turned on.

8. Defrost Function

The Controller's defrost sensor value operates as follows:

- If the Defrost sensor temperature measures $\leq 2^{\circ}\text{C}$, the compressor is turned off and the defrost system is turned on.
- If the Defrost sensor temperature measures $\leq 8^{\circ}\text{C}$, the compressor is turned on and the defrost system is turned off.

9. Shut Off Procedure

Pressing the Power Switch (1) to the “OFF” position, shuts down the Air Conditioning System.

OPERATING INSTRUCTIONS

Service Intervals / Maintenance Schedule

Air Conditioning

IMPORTANT: The air conditioning system must be run for a minimum of five minutes each week regardless of the season to lubricate the system and prevent damage to the seals.

To ensure dependable efficient operation, all air conditioning units require a certain amount of Preventative Maintenance to be carried out at regular intervals between services.

These regular inspections will ensure that the unit is always operating at peak efficiency and will provide early warning of potential problems, which if left unattended, may incur costly machine down-time.

It is strongly recommended that an annual service program be implemented. This full unit service should be carried out once a year, generally just prior to the beginning of the warmer season.

This service should only be carried out by a qualified refrigeration mechanic and should involve a full function test of the complete system, as well as checking of component settings.

The following tables shown are our suggested maintenance schedule for all units.

DAILY INSPECTION	
Component / System	Inspection Required
Return Air Filters	Check for cleanliness and deterioration
Refrigeration Hoses	Check for damage or deterioration
Fresh Air Filtration	Check pre-cleaner for damage or deterioration

MONTHLY INSPECTION	
Component / System	Inspection Required
Condenser Coil	Check for cleanliness
Evaporator Coil	Check for cleanliness
Condenser Fan Motors	Clean motors with dry compressed air

OPERATING INSTRUCTIONS

Service Intervals

THREE-MONTHLY INSPECTION

Component / System	Inspection Required
Condenser coil	Check refrigeration connections against leakage. Check coil support bolts.
Condenser fan motor	Check motor support clamps and screws. Check shaft bearings and brushes for wear. Check electrical connections.
Condenser fan	Check for excessive noise during operation. Check for blade damage. Check securing screws.
Compressor	Check refrigeration connections against leakage. Check securing bolts. Check anti vibration mounts. Check for excessive noise during operation.
Receiver drier	Check refrigeration connections against leakage. Check securing bolts. Check for system charge in sight glass during operation.
High/Low pressure control	Check electrical connections.
Evaporator coil	Check for refrigerant leakage. Check coil securing screws.
Evaporator fan motor	Check motor support clamps and screws. Check shaft bearings and brushes for wear. Check electrical connections.
Evaporator fan	Check for excessive noise during operation. Check for blade damage. Check securing screws.
Thermal expansion valve	Check refrigerant connections against leakage.
Thermostat	Check electrical connections.
Control switches	Check electrical connections. Check operation.
Supply air louvres	Check for damage and cleanliness.
Condensate drip tray	Check for cleanliness. Check for drainpipe blockage.
Main frame and panels. Unit mounting	Check securing screws and catches. Check securing screws. Check plenum seal for leaks.
Refrigeration lines Fresh air fan motor	Check for excessive noise during operation. Check motor support clamps and screws. Check shaft bearings and brushes for wear. Check electrical connections.

DAILY INSPECTION

Component / System	Inspection Required
Compressor	Check compressor belts for wear, tightness and alignment. Replace and adjust as necessary. Check Oil Level.
Condenser Coil	Hose condenser coil clean being careful not to use excess pressure, which can damage coil finning. (More frequent service may be required in dusty applications.)
Evaporator Coil	Check and if necessary clean.
Performance Test	Carry out full components and system performance test using a Gauge Manifold Set.

MONTHLY INSPECTION

Component / System	Inspection Required
Evaporator Coil	Remove evaporator coil and thoroughly clean being careful not to use excess pressure, which can damage coil finning. Straighten finning.
Receiver Drier	Replace receiver drier. (Indicative only, always replace receiver drier when the system has been opened.)
Supply Air Fan	Remove and clean fan assemblies and check for bearing wear and noise.
Condenser Fans	Remove and clean fan assemblies and check for bearing wear and noise
Evaporator Fans	Remove and clean fan assemblies and check for bearing wear and noise
Compressor	Check compressor oil level and bearings.
Evaporator Drain Tray	Check for blockage of condensate drains.

OPERATING INSTRUCTIONS

Component Maintenance

Replenishing Refrigerant

“Flashing” in the liquid line sight glass of a previously charged system indicates an inadequate charge of refrigerant and replenishment is accomplished with the plant running.

Before replenishing a thorough leak test with a halogen leak detector is required so that the offending leak can be located and rectified.

To replenish proceed as follows:

1. Loosely connect the charging line from the cylinder of refrigerant to the suction service valve situated on the compressor. Purge the charging line.
2. Ensure that the charging line connection to the cylinder is fully secure and that the cylinder is vertical.
3. Tighten the charging valve/charging line connection.
4. Open the charging valve slowly.
5. Add refrigerant until a steady liquid flow in the sight glass indicates a fully charged condition. This can be accomplished by adding a small amount of refrigerant at a time.

CAUTION: Particular care should be taken when adding refrigerant as an overcharge of refrigerant causes excessive head pressures which in turn can cause considerable damage.

6. Backseat the suction service valve, but do not disconnect the cylinder at this stage.
7. Allow running conditions to stabilise and check the sight glass and discharge pressure. Add more refrigerant should flashing occur.
8. On completion of the replenishment, tightly backseat the suction service valve and remove the charging line. Fit a sealing cap to the line before storing.

Coils

“Flashing” in the liquid line sight glass of a previously charged system indicates an inadequate charge of refrigerant and replenishment is accomplished with the plant running.

If cleaning is required wash with low pressure, mains temperature water in the reverse direction to the air flow. For evaporator coil ensure a baffle is used to prevent any water from entering cabin through the return air plenum.

WARNING: DO NOT brush coil fins with a wire brush as irreparable damage may occur. If fins are bent, use only the correct fin comb to straighten them.

Fan Motors

Check the motors for excessive shaft endplay. Brushes are accessible by removing the two plastic brush caps on each motor.

Note: Before removing brush caps thoroughly clean the motors using water-free compressed air.

Fan Blades

Check the fan blades for wear or damage. Check that blades are tight on motor shaft.

Any damaged/worn blades should be replaced - **DO NOT repair.**

Fresh Air Filter (Pressuriser)

The fresh air pressurising filter is located inside the filter housing of the pressuriser unit. The fresh air filtration system is comprised of a pre-cleaner plus a filter element.

Both of these items should be checked at regular intervals for signs of damage or deterioration. To service fresh air filtration systems proceed as follows –

1. Remove pre-cleaner bowl (if fitted) from top of filter housing. Clean out accumulated dust and refit bowl.
Note: Take care not to over-tighten knurled knob on top of pre-cleaner bowl cover.
2. Unclip or unscrew the filter housing and remove the cover.
3. Remove and clean the filter element by gently tapping on a firm surface - **DO NOT wash.**
4. Check the rubber seals at the base of the filter element for damage or deterioration.
5. Remove accumulated dust from filter housing.
6. Refit the filter element, ensuring that it seats correctly and replace cover.

Receiver Drier / Inline Drier

This is a fully sealed, non-serviceable component which should be renewed whenever the refrigerant system is ‘opened’. After renewal of the receiver drier the system must be evacuated and recharged.

The drier is isolated to minimise gas loss on replacement.

To remove:

1. Shut off line valve at condenser coil outlet
2. Run compressor and pump down liquid line.
3. Shut off line valve upstream of drier.
4. Remove and replace.

Note: Ensure both line valves are reopened once drier is replaced. An access port is provided to evacuate this section prior to re-opening.

Pressure Control Switch

This is a fully sealed, pre-set, non-serviceable component. It should be noted that this is fitted on Schraeder valves and can be replaced without loss of gas.

Component Maintenance

Electronic Thermostat

This item is fully sealed and a non-serviceable item.

Please refer to FAULT DIAGNOSIS section to ensure correct operation if required.

Thermal Expansion Valve

This valve is factory set to provide the correct balance of pressure and temperature at the evaporator.

Service on this valve is limited to the removal and cleaning of the wire gauze filter at the valve inlet.

To remove the filter proceed as follows:

1. Shut off line valve upstream of TX valve.
2. Run compressor and pump down evaporator coil and suction line.
3. Close compressor suction service valve.
4. Remove the lagging compound from around the valve.
5. Remove the valve assembly from the refrigeration system.
6. Using a sharp instrument carefully prise out the conical shaped strainer from the inlet port.

Note: Care must be taken not to tear the wire gauze.

7. Carefully wash the gauze in a suitable solvent.
8. Installation is a reversal of the above procedure.
9. Ensure line and service valves are reopened once complete.

WARNING: If the filter blockage is due to a concentration of small white balls it is possible that the desiccant has become dislodged within the receiver drier.

If this is the case, the entire system will have to be flushed out and a new receiver drier installed.

Compressor

For compressor service refer to relevant manufactures service manuals.

Return Air Filter

The return air filter should be removed and washed as required, under cleaned running water, as noted on the Maintenance Schedule Chart.

Specifications - HIGH-CAPACITY HEPA PRESSURISER

Blower	: Brushless Blower P/N 200002
Protection	: Locked Rota (Sub Zero Environments) Under Voltage, Under/Over Current & Over Temperature
Voltage	: 24v
Current Draw	: 11 amps (peak). *Note Brushless Motors on excessive in rush current on start up.
Air Flow	: Up to 30-300 m ³ /h or 50-215 CFM.
Pre-cleaner	: Integrated VLR (Very Low Restriction). Turbo Pre-Cleaner
Filter Element	: BreatheSafe HEPA Primary Filter (H14=99.99% MPPS) TESTED AS PER EN1822 – P/N 500000
Plugs & Fittings	: Mining Spec. Deutsch electrical plugs as standard.
Construction	: High strength composite construction.
Serviceability	: Easy access HEPA filter with twist-lock (TL) dust cap single assembly.
Finish	: Satin Powder Coated throughout (Ducting).
Mounting	: Heavy Duty adjustable mounting brackets.
Design	: Fully designed in SolidWorks 3D CAD & Ansys Engineering Simulation Software.
FEA Testing	: Critical components FEA (Finite Element Analyst) tested in Solid Works Simulation.
CDF Testing	: CFD (Computational Fluid Dynamics) simulations in Flow Works to ensure optimum air flow through the system.

SPECIFICATIONS - HIGH-CAPACITY HEPA PRESSURISER

List of Abbreviations	
DH	Dual HEPA
DHPR	Dual HEPA Powered Recirculation
DHAC	Dual HEPA Activated Carbon
DHACPR	Dual HEPA Activated Carbon Powered Recirculation
CPM	Cabin Pressure Monitor
CPU	Central Processing Unit
DB	Decibel Sensor
DPM	Diesel Particulate Matter
GAS	Gas Sensor
HEPA	High-Efficiency Particulate Air Filter
HPAFU	High Pressure Air Filtration Unit
HRAF	HEPA Return Air Filter
HVAC	Heating Ventilation and Air Conditioning
MAF	Mass Air Flow
OEM	Original Equipment Manufacturer
PM	Particulate Mass
RH	Relative Humidity
TEMP	Temperature
TS	Touch screen
UI	User Interface
VMS	Vehicle Monitoring System
VS	Vibration Sensor
OGSP	OnGuard Sensor Pod
CO2s	CO2 Sensor INPRESS TS

Specifications - AIR CONDITIONING SYSTEM

SPECIFICATIONS – AIR CONDITIONING

Coil	: Aluminium Fin, Copper Tube Condenser Coil complete with anti-corrosive powder coat finish.
Capacity	: 8Kw
Fans	: 2x Brushless EBM Axil Fan Motors
Voltage	: 24v
Current Draw	: 5amps (peek) per fan, 10 amps (peek) total
Air Flow	: 1920 m3/h (per fan)
Plugs & Fittings	: Mining Spec. Deutsch electrical plugs as standard.
Construction	: Heavy duty plate, laser cut, CNC formed & fully welded.
Serviceability	: Fully hinged lid complete with flush fitting Cam locks.
Finish	: Satin Powder Coated throughout or Stain Steel 316
Mounting	: 6 x Easy Access Mounting Points
Design	: Fully designed in SoildWorks 3D CAD
FEA Testing	Critical components FEA (Finite Element Analyst) tested in SolidWorks Simulation
CDF Testing	CFD (Computational Fluid Dynamics) simulations in FlowWorks to insure optimum air flow through the system.

WIRING – AIR CONDITIONING

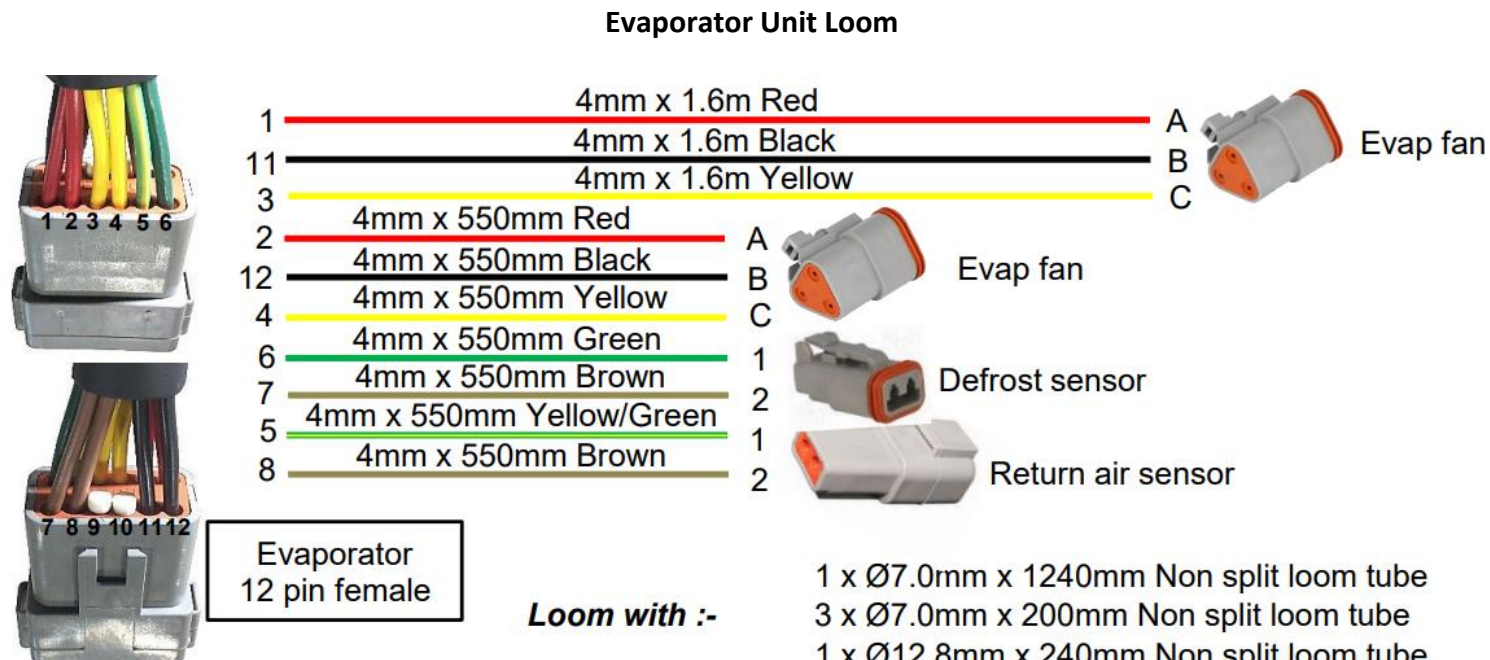

Loom with :-

- 1 x Ø7.0mm x 1240mm Non split loom tube
- 3 x Ø7.0mm x 200mm Non split loom tube
- 1 x Ø12.8mm x 240mm Non split loom tube

Wiring

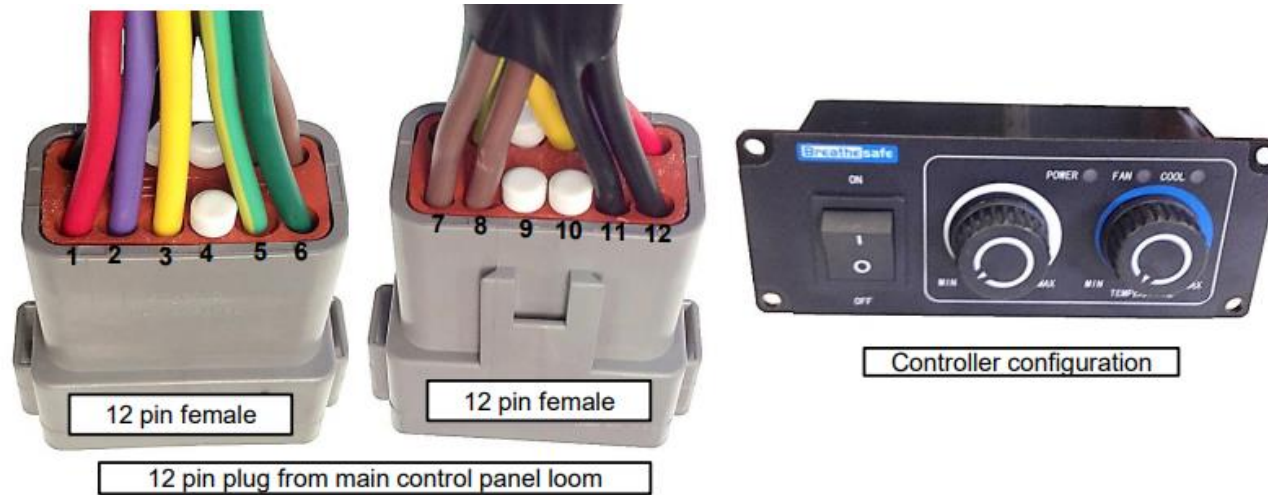

Note :- White control wire off controller is substituted with "Yellow" into 12 pin plug - Location №3

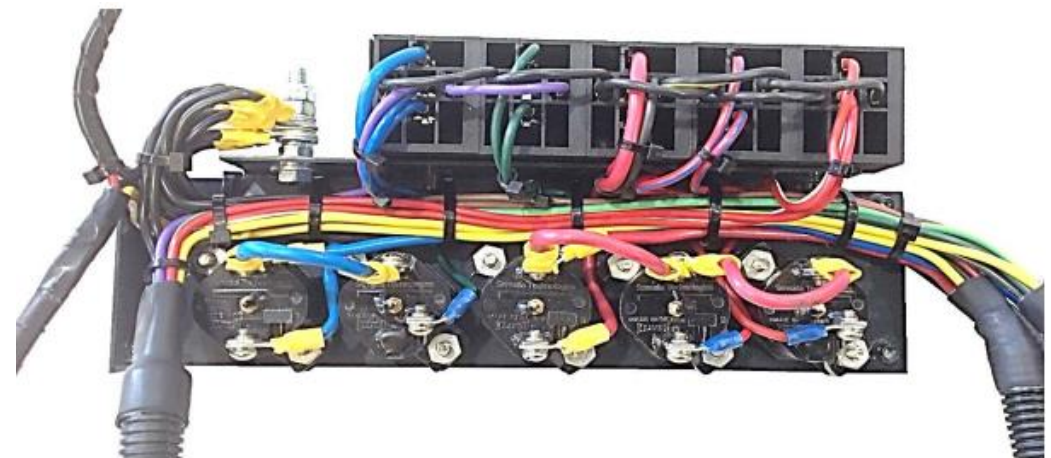

WIRING – AIR CONDITIONING

Wiring

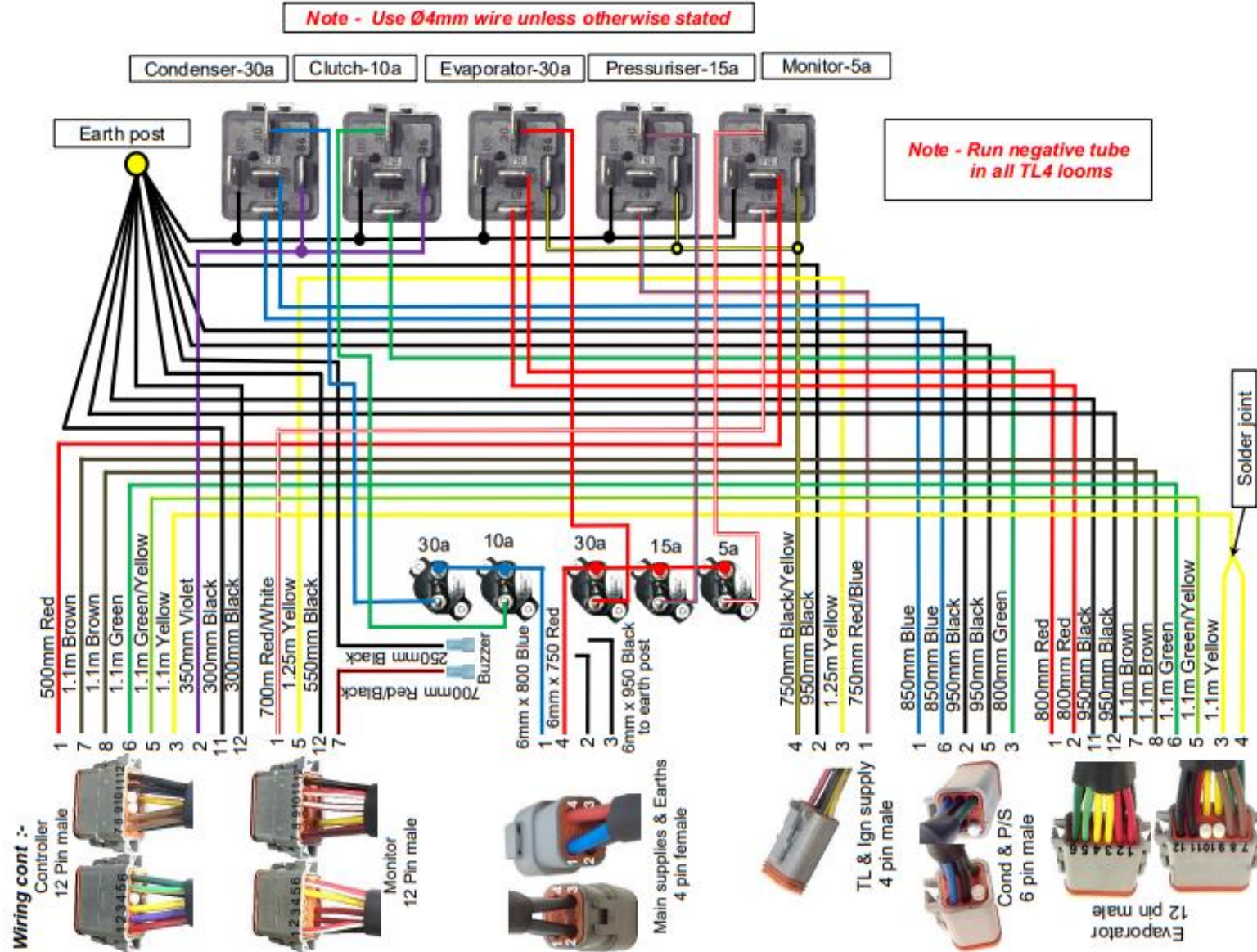

WIRING – AIR CONDITIONING

Wiring

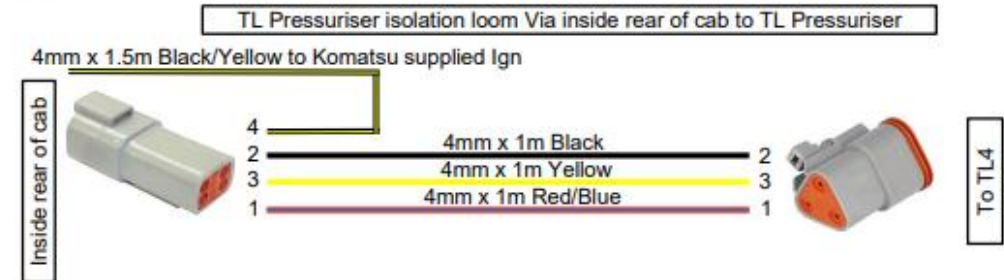
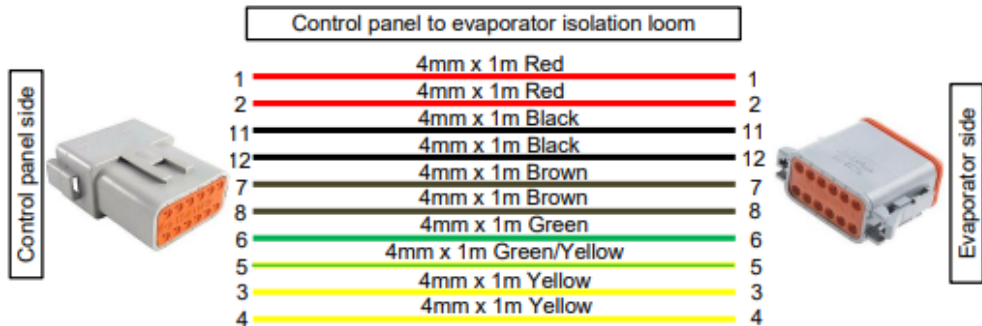
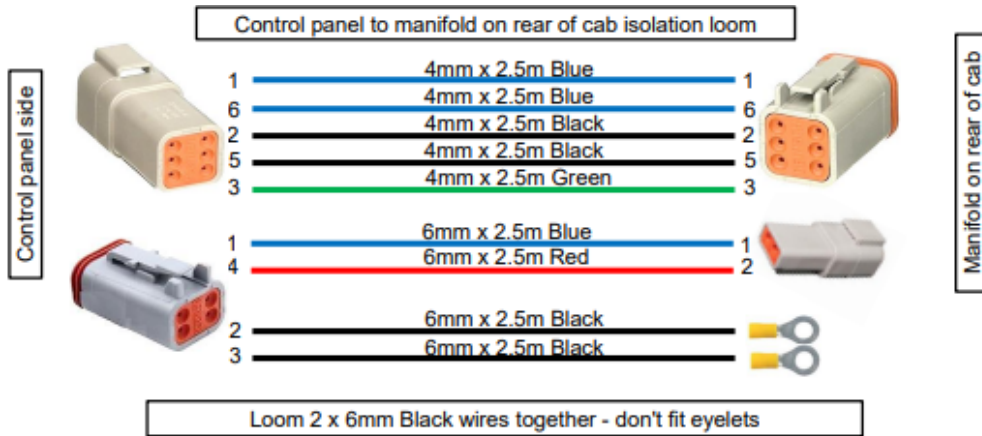

Commissioning Procedure – Air Conditioning System

COMMISSIONING PROCEDURES – AIR CONDITIONING SYSTEM

Step One:

If a new system, evacuate for a minimum period of four hours. If the system has been opened to undergo repairs an evacuation period of one hour should be sufficient provided connections have been capped during the repair period. The filter/drier should be changed.

Early in the evacuation period close valves on the gauge set for several minutes to see if gauge needles remain stationary. If they do it is an indication that the system is leak free; if they move back towards zero a leak is indicated and leak testing procedure should be implemented and the leak corrected (*please see [Nitrogen Leak Testing](#) for general instructions*).

Step Two:

At the end of the evacuation period partially charge the system with R134a vapour into the compressor suction service valve and recheck the whole system for leaks (*please see [System Evacuation](#) for further details*).

Step Three:

Turn the thermostat to its coldest setting: run the engine at fast idling speed and charge the system; do not use liquid in the charging process (*please see [System Charging](#) for further details*).

Step Four:

With the lid of the unit closed, run engine up to maximum rpm.

Step Five:

Note compressor discharge and suction pressures and check the feel and condition of the compressor suction service valve.

Step Six:

If the discharge pressure is within the 820 to 1300 kPa (120 to 190 Psi) range, the suction pressure should be in the 70 to 138 kPa (10 to 20 Psi) range when ambient temperature is above 21°C and the cabin temperature is down to comfort conditions.

Step Seven:

At higher or lower ambient temperatures, the gauge reading will vary accordingly. (In winter conditions, position the vehicle in the sun with maximum solar penetration of cab glass; blank or partially blank fan intake using sheet metal or cardboard to raise discharge pressure to nominal 820 kPa (120 Psi).

Step Eight:

To provide adequate compressor cooling and maximum evaporator coil performance, gas returning to compressor should be cold and the suction service valve cold and sweaty but NOT icing.

Step Nine:

When the thermostat is set to the minimum setting, it is necessary to ensure the evaporator cannot ice up under low return air temperatures, on high or low fans and with the compressor running at maximum speed.

IMPORTANT

The air conditioning system must be run for a minimum of five minutes each week regardless of the season to lubricate the system and prevent damage to the seals. Ensure a qualified technician is employed for any repairs required.

Proceed to online commissioning:

[Commissioning - BreatheSafe](#)
 [\(breathe-safe.com.au\)](http://breathe-safe.com.au)

COMMISSIONING – NITROGEN LEAK TESTING

Nitrogen Leak Testing – General Instructions

Legislation on handling refrigerants requires leak testing of the system following any dismantling of major components.

The procedure to do this is as follows:

1. Connect a cylinder of dry nitrogen to the compressor valve on either of the suction or liquid line connections.
Note: It is important that the nitrogen charging set is supplied with a shut-off valve pressure reducing valve, cylinder pressure gauge and bleed valve.
2. Set the cylinder reducing valve to 1035 Kpa (150 psig)
3. Open the nitrogen cylinder shut-off valve and charge the plant up to a test pressure of 1035 kPa (150 psig).
4. Close the cylinder shut-off valve.
5. All joints should be vibrated by tapping carefully with a rubber or soft hide-faced mallet.
6. Test for leaks with a soap and water solution.



COMMISSIONING

System Evacuation

A moisture free refrigerant system is essential for the correct functioning of the unit. Moisture can cause freezing and blockage at control points, etc, or the formation of hydrochloric acid when in contact with refrigerant, with detrimental effects upon valves, bearings, seals, etc.

The manifold has fittings to receive the gauges and hoses and hand valves, which provide control of the refrigerant through the manifold. The manifold gauges are connected to the compressor service valves by hoses.

The high side gauge measures pressure on the discharge side of the compressor.

The low side gauge registers both pressure and vacuum. The vacuum side is utilised to record the vacuum pulled, during evacuation of the system, in inches of mercury. The pressure portion of the gauge scale is used to record the pressure on the suction side of the compressor during unit operation.

The hand valves are utilised to open or close the gauge pressure ports. When the valve is turned all the way in (clockwise), the manifold port is closed and the pressure gauge is open to the pressure hole. The pressures on that side of the system will be recorded on the gauge above the hose. Opening the valve fully (anti-clockwise) opens the system to the middle service port of the manifold set. This is done only to let refrigerant into or out of the system, or for evacuating the system.

Refer to the diagram right for correct connection of evacuation circuit components.

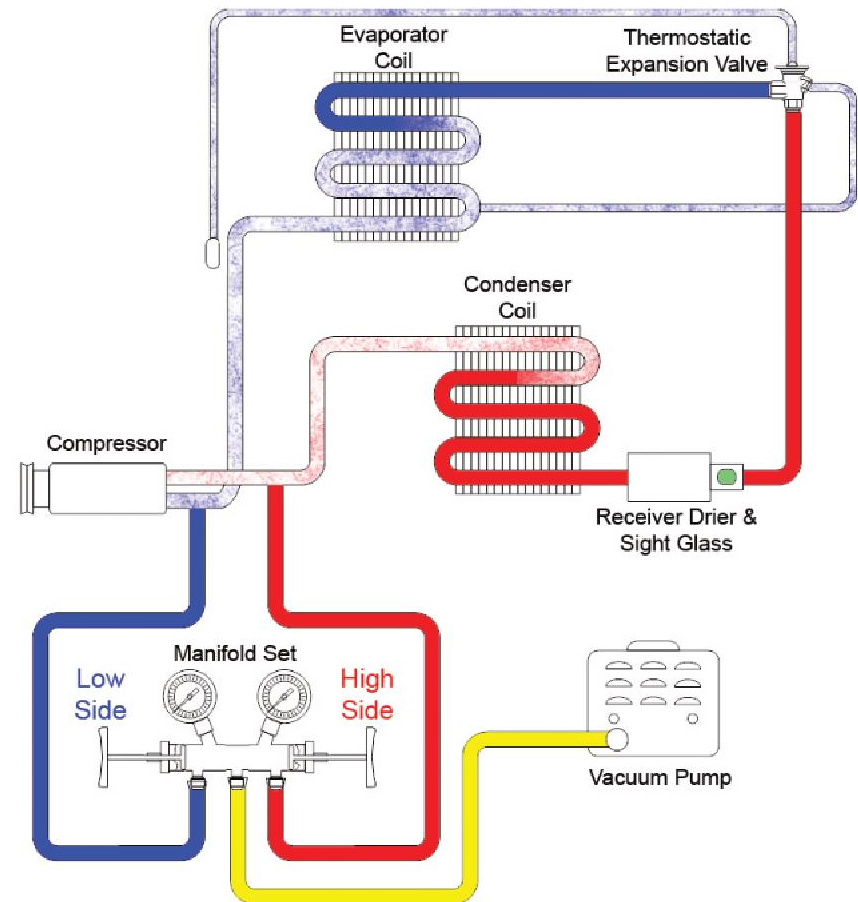

COMMISSIONING

System Evacuation

To correctly evacuate the system proceed as follows:-

1. Check the compressor suction and discharge service valves are both open, ie. midway between being fully front-seated or fully back-seated.
2. Attach the manifold gauge set to the compressor service valves. Close the manifold set hand valves. Note: Ensure that the manifold gauge set hoses are equipped with "dill Depressor" fittings to enable opening of the Schrader valves.
3. Connect the service (centre) hose on the gauge set to the intake port on the vacuum pump.
4. Ensure that the vacuum pump discharge valve is closed.
5. Switch the vacuum pump on and open the hand valves on the gauge set. Open the vacuum pump discharge valve after the vacuum pump has started. Low pressure gauge should quickly pull down to 0.5mm Hg. of vacuum on the low side gauge of the manifold gauge set.
6. Evacuate for 5 minutes then close both hand valves and switch off the pump. If the low pressure gauge holds a steady vacuum for 5 minutes, that is a good indication there are no leaks in the system.
7. Switch on the pump and open the hand valves on the gauge set. Evacuate for a minimum one hour.
8. When the evacuation is complete close both hand valves, switch off the pump and disconnect the service hose from the pump.
9. Fully back seat both compressor service valves.

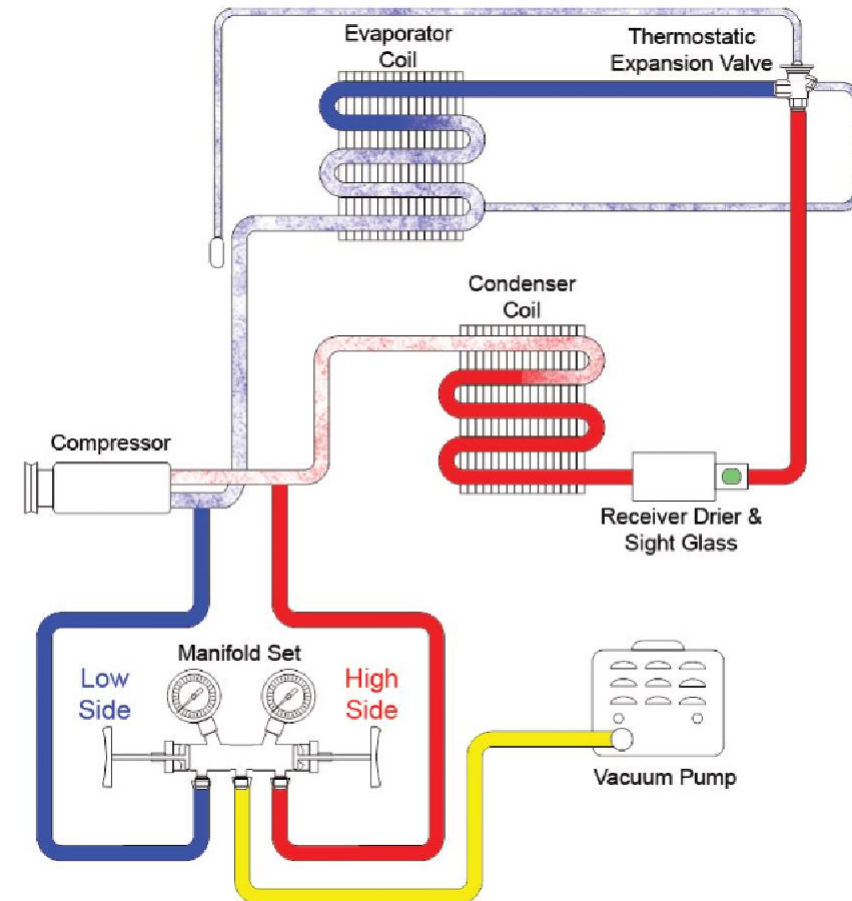

COMMISSIONING

System Charging

The charging operation should be performed at air temperatures of 21°C and above.

Changes in ambient air temperatures, and to a lesser degree humidity, will affect the system's ability to take a charge and will vary gauge readings. Please refer to the table below for the suggested pressure readings in the ambient temperatures being experienced during system charging.

Ambient Temp. (°C)	COMPRESSOR	
	Discharge Pressure (kPa)	Suction Pressure (kPa)
16 °	850 - 1200	20 - 100
21 °	1050 - 1750	20 - 100
27 °	1250 - 1900	20 - 100
32 °	1400 - 2150	30 - 150
38 °	1600 - 2300	30 - 200
43 °	1900 - 2500	30 - 250

When adding partial charge to a system it is not necessary to discharge and evacuate if there is no evidence of air in the system and there are no system leaks.

Note: Up to 0.2kg of refrigerant loss per year is considered normal. Operating the unit periodically during the off-season will lubricate system seals and reduce the possibility of refrigerant loss.

To correctly charge the system refer to diagram below and proceed as detailed in the Systems Charging section.

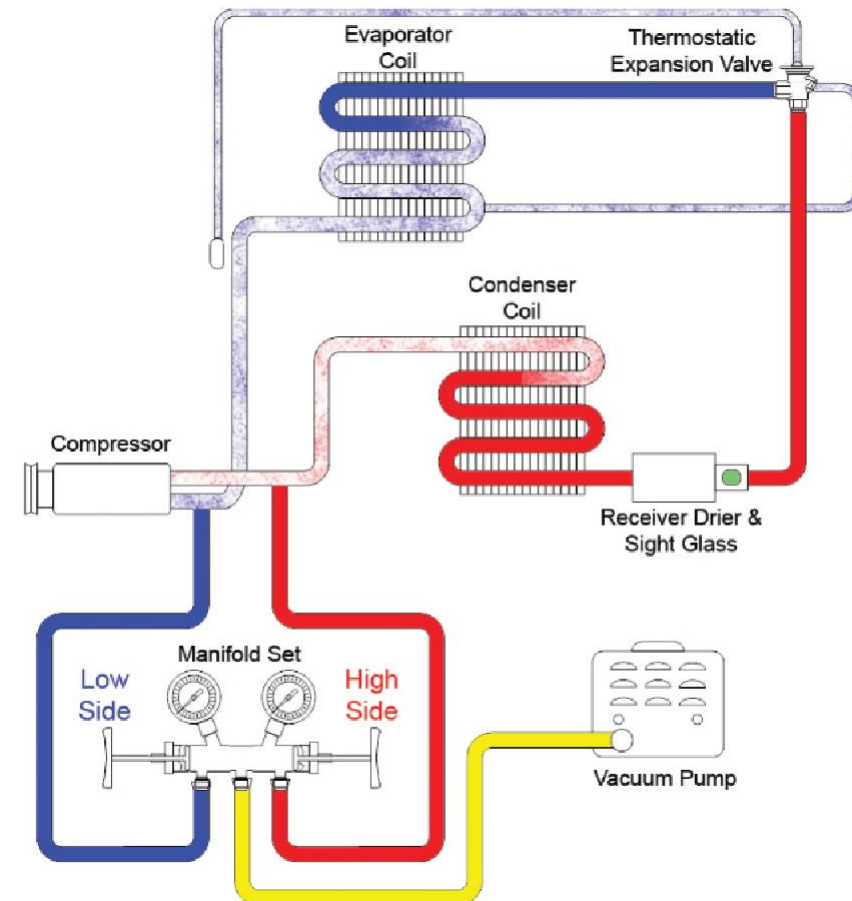

COMMISSIONING

System Charging

1. Install gauge set and purge hose if a partial charge is to be added. Gauge set should already be installed and holding a vacuum if a full charge is to be added. The manifold hand valves should be closed.
2. Loosely connect the charging line from the cylinder of R134a refrigerant to the manifold gauge set.
3. Ensure that the charging line connection to the cylinder is fully secured and that the cylinder stands vertically upwards, to ensure that only refrigerant vapour can be charged into the system

WARNING: DO NOT invert the R134a container. Liquid refrigerant entering the low side of the system will permanently damage the compressor.

4. Crack the cylinder valve sufficiently to purge the charging line and then tighten the charging line connection onto the manifold.
5. Return the compressor suction service valve to the midway position to open the charging port.
6. Run the engine at 1500 r.p.m., select HIGH COOL on the Main Control Switch.
7. Slowly open the low-pressure gauge manifold hand valve allowing the system to draw refrigerant vapour from the charging cylinder.

WARNING: DO NOT open the high-pressure gauge hand valve while charging.

8. Continue charging until the bubbles disappear from the receiver drier sight glass. At this point the system should be fully charged with 2.8 kg of R134a.
9. Close the low-pressure gauge hand valve and switch off the engine.

10. Test the complete system for leaks, especially around hose connections.
11. Fully back-seat the compressor suction service valve, close the charging cylinder valve and disconnect the charging hose.
12. Fit the compressor suction valve sealing cap.
13. Adequately seal all hoses and fittings before storing.

Note: If it is necessary to change the refrigerant cylinder during the charging procedure, the low-pressure gauge hand valve must be tightly closed before disconnecting the empty cylinder. On fitting the full cylinder, it will be necessary to purge any air from the charging hose before opening the hand valve and continuing with the charging operation.

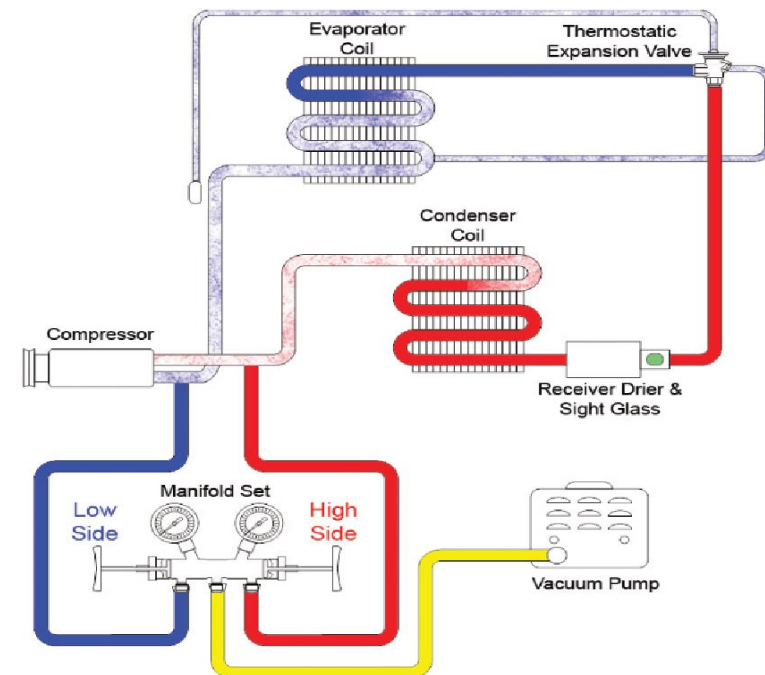

FAULT DIAGNOSIS

Fault Diagnosis Overview

Our flowcharts are included as an aid in trouble shooting the air conditioning system should it develop a fault.

In many cases, a problem that causes an air conditioning system to malfunction requires little time to investigate and repair. These possible causes should be the first to be examined and corrected.

Use the flow charts, in conjunction with the gauge set to determine the cause of the problem and then carry out the remedy prescribed.

As a general guide to correct system performance, the Discharge / Suction Table is included to show the acceptable discharge and suction gauge pressures against the ambient temperature during unit operation.

To use the Discharge / Suction Table proceed as follows:

1. Set air conditioning fan speed switch to "HIGH FAN".
2. Set mode switch to "COOL" position, and thermostat to "COOLER" position.
3. Record ambient temperature.
4. Check pressure in table against applicable ambient temperature.

Discharge – Suction Table



Ambient Temp. (°C)	COMPRESSOR	
	Discharge Pressure (kPa)	Suction Pressure (kPa)
16 °	850 - 1200	20 - 100
21 °	1050 - 1750	20 - 100
27 °	1250 - 1900	20 - 100
32 °	1400 - 2150	30 - 150
38 °	1600 - 2300	30 - 200
43 °	1900 - 2500	30 - 250







Refrigerant Sight Glass

The refrigerant sight glass incorporated in the top of the receiver drier, can be a valuable aid in quickly determining the cause of a system malfunction

For correct interpretation of sight glass indications, the following table has been included for your reference.

Sight Glass Indicator Table

	Clear	Indicates that the system has correct refrigerant charge. It may also indicate a complete lack of charge or overcharge, both of which can only be checked with gauges.
	Foamy	Indicates that the system is low on charge and probably contains air. Occasional bubbles at start-up is normal.
	Oil Streaks	Indicates lack of charge and compressor oil is circulating through system.
	Cloudy	Indicates dessicant contained in receiver drier has broken down and is circulating through the system.
	Occasional Bubbles	Indicates system slightly low on charge. Receiver drier may be saturated and releasing moisture into the refrigerant system.

FAULT DIAGNOSIS

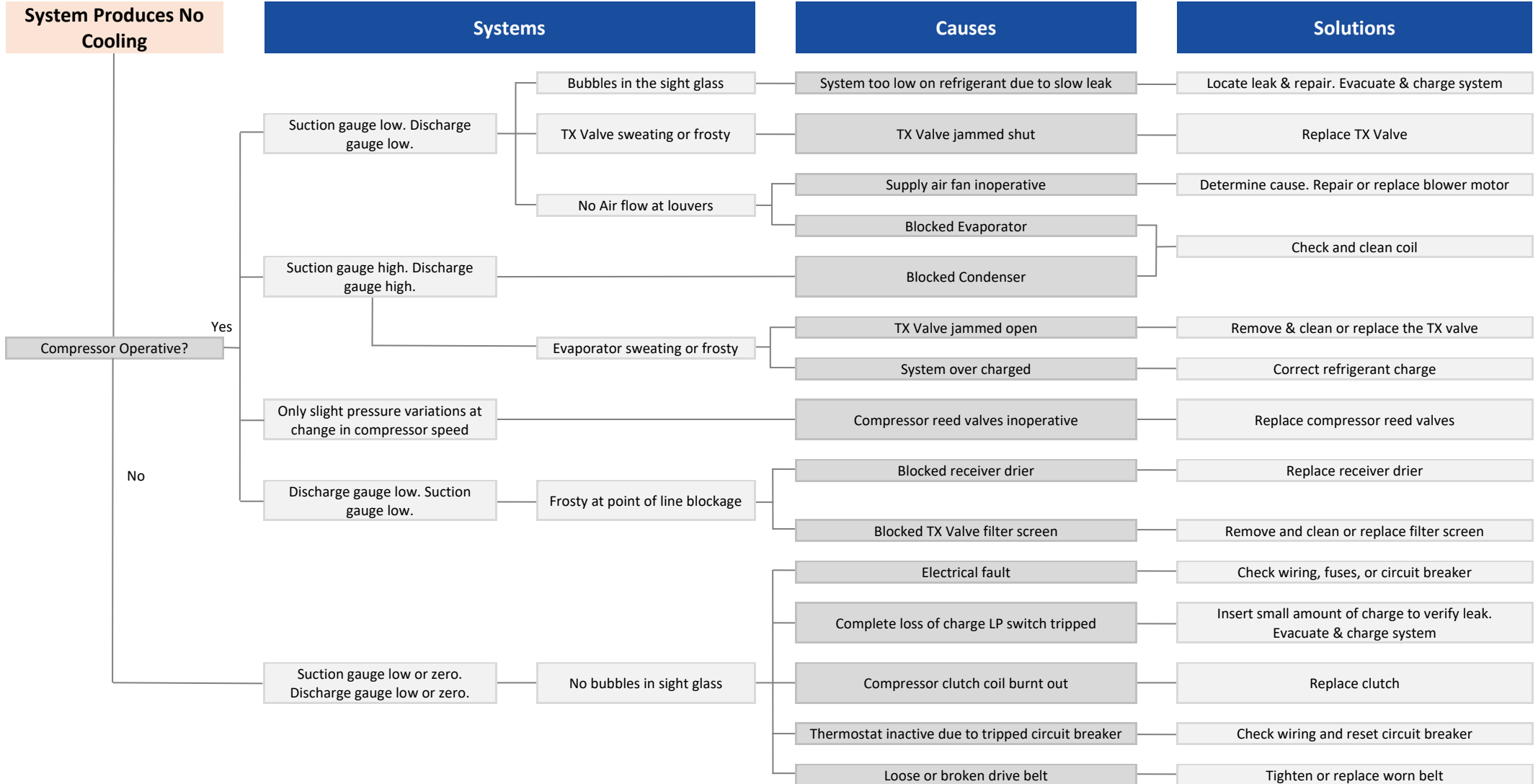

FAULT DIAGNOSIS

System Only Partially Cools

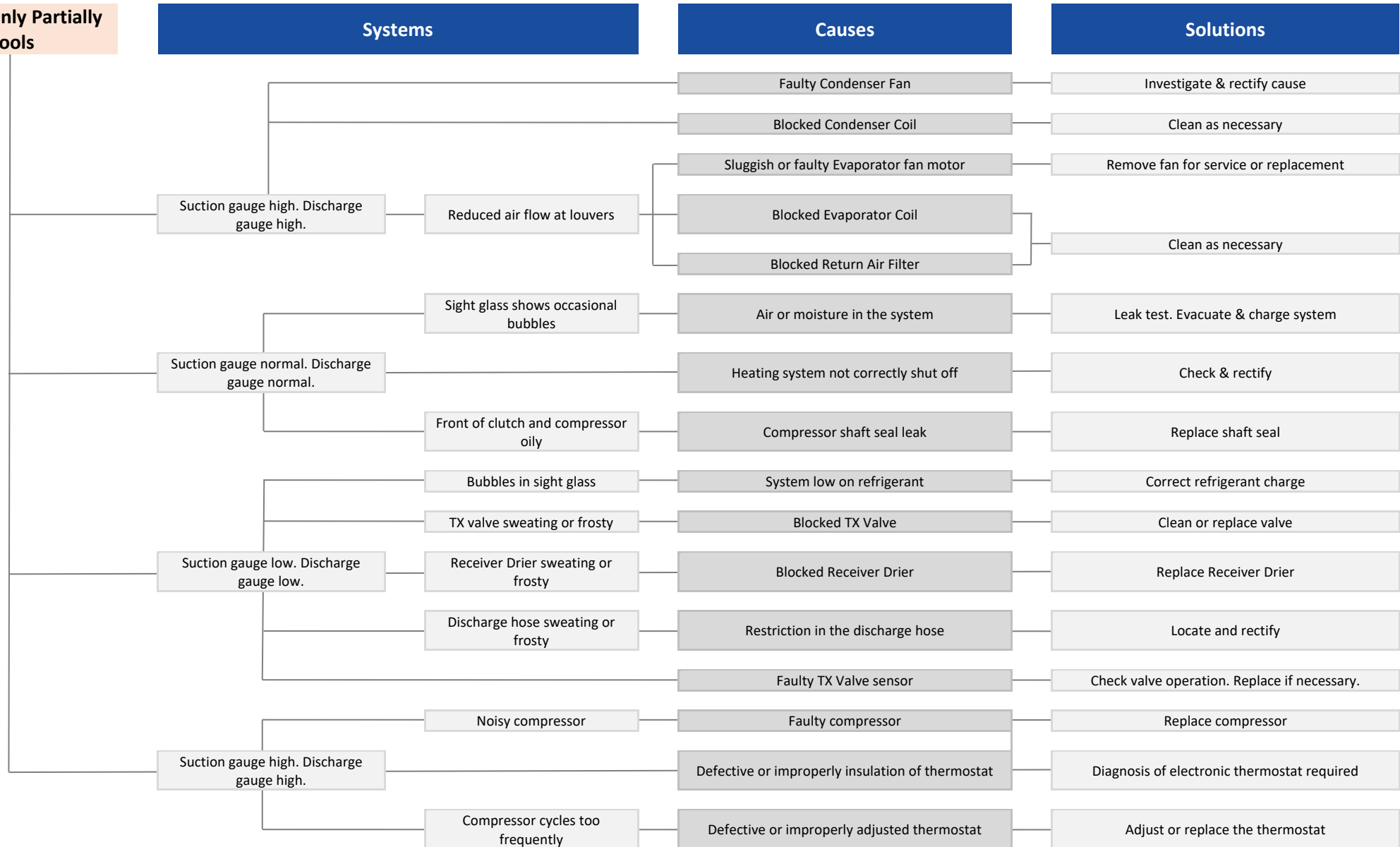

FAULT DIAGNOSIS

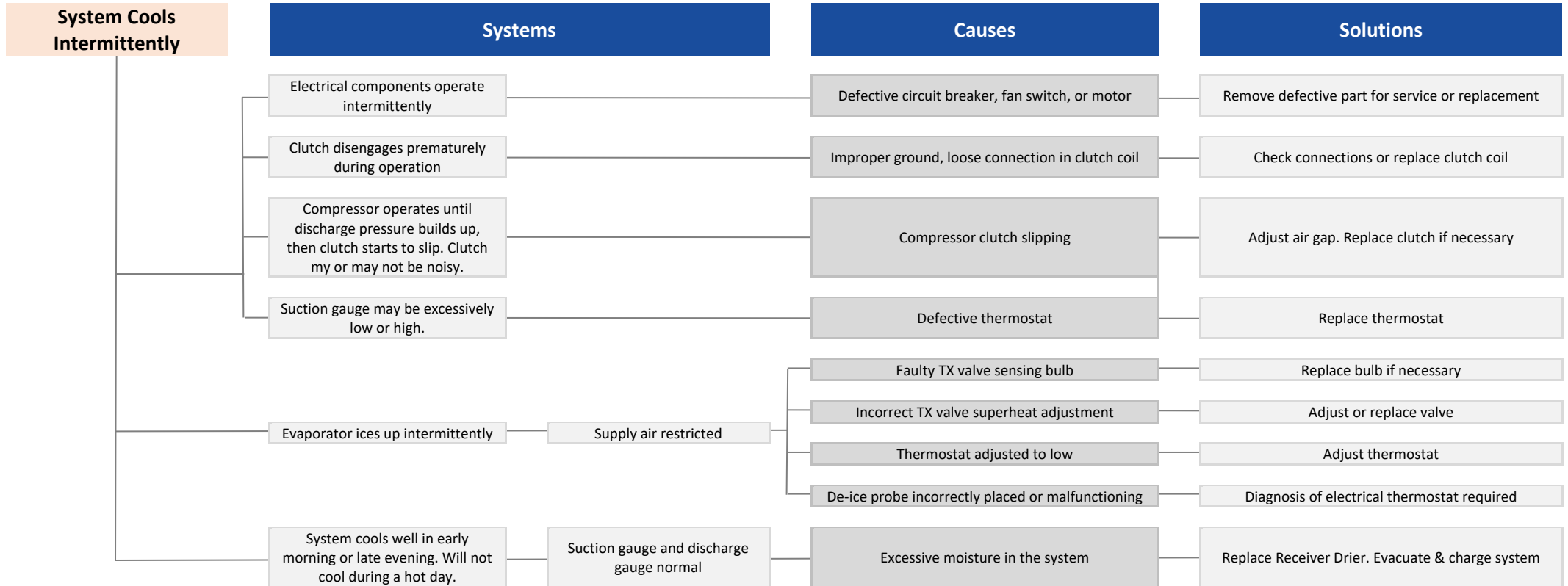

FAULT DIAGNOSIS

System Is Excessively Noisy

Systems	Causes	Solutions	
Idler pulley whines or growls. Pulley has rough spots when rotated by hand.	Worn bearings	Replace pulley bearing	
Clutch vibrates – may slip	Defective coil winding. Improper coil connection.	Repair or replace as necessary	
Belt slips and are noisy	Loose or worn drive belts	Tighten or replace as necessary	
Compressor vibrates	Loose or worn compressor	Check mounting. Remove compressor for service or replacement	
Unit emits a rattling noise	Loose panels. Hose or pipes vibrating. Loose compressor inside the unit.	Thoroughly check unit panels and components	
Noisy compressor	Suction gauge high. Discharge gauge low.	Faulty compressor	Replace compressor
		Low compressor oil	Check & rectify
	Rumbling noise from the system. High discharge or suction pressure. Bubbles present in the sight glass.	System overcharged	Correct system charge
	Discharge gauge high	HP service valve closed	Open valve immediately
	Low suction or discharge pressure. Bubbles present in the sight glass	Low system charge	Check system for leaks. Charge system
TX Valve noisy	Suction gauge low	Excessive moisture in the system	Replace Receiver Drier. Evacuate & charge system
Noisy evaporator fan	Worn motor bearings or bushes. Damaged or loose fan blades or fan cowlings	Remove blower for repair or replacement	
Noisy condenser fan			

FAULT DIAGNOSIS

Fault Analysis Chart Notes

3. **CLOGGED STRAINER OR FILTER** Occasionally the strainer or filter in the liquid line may become clogged with foreign material left in the system during installation. When this happens, the liquid line leaving the strainer will feel cooler than the liquid entering. It is badly clogged, some sweat or frost may appear at the strainer outlet.
4. **THERMAL EXPANSION VALVE LEAKS** At the end of the evacuation period partially charge the system with R134a vapour into the compressor suction service valve and recheck the whole system for leaks.
5. **THERMAL EXPANSION VALVE STUCK IN OPEN POSITION** If the expansion valve is stuck in an open position, there will be an excessive amount of sweating on the suction line and compressor crankcase due to the large amount of liquid being passed into the suction line. The expansion valve should be checked for loss of charge or faulty thermal bulb contact with the suction line.
6. **POWER ELEMENT** The power element of an expansion valve consists of the thermal bulb, capillary tube and the bellows or diaphragm which actuates the valve pin. If this power element is defective or has lost its charge, the valve will either maintain an almost closed position or may close completely. To test for a defective power element, the thermal bulb should be removed from the suction line and warmed by holding it tightly in the hand. The valve will open if the power element is not defective. If the power element is defective, the valve will remain closed.
1. **THERMAL EXPANSION VALVE IMPROPERLY ADJUSTED** If the expansion valve is adjusted for too low a superheat, too much liquid will be passed to the evaporator. The suction line will be abnormally cold and liquid may “slug” back to the compressor. If the expansion valve is adjusted for too high a superheat, too little liquid will be passed to the evaporator and the suction line will be abnormally warm. Superheat should always be adjusted carefully using thermometer and suction gauge.
2. **THERMAL EXPANSION VALVE TOO LARGE** If a replacement thermal expansion valve has been improperly selected, and its capacity is too great for the system, the valve will not maintain a consistently level suction pressure. The thermal bulb will attempt to control the flow of liquid at its superheat setting, but the oversized valve port will pass liquid too rapidly. The presence of liquid near the thermal bulb will close the valve and the pressure in the evaporator will drop until the valve opens to pass another “slug” of liquid. This “hunting” will cause a suction pressure variation noticeable on the suction pressure gauge.

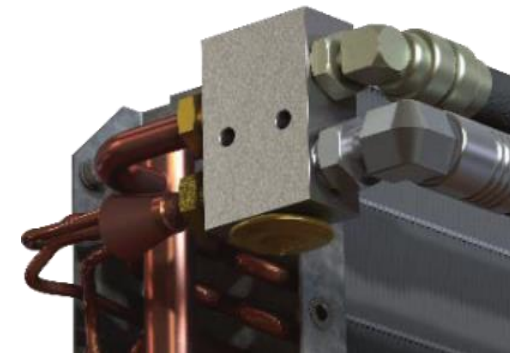

FAULT DIAGNOSIS

Fault Analysis Chart Notes

7. Thermal Expansion Valve Too Small

If the replacement thermal expansion valve is too small, it cannot pass a sufficient amount of liquid to satisfy the evaporator. Under conditions of heavy load, the super-heat will be excessive and the system will lose capacity. Under conditions of light load, the system may function properly. Too small expansion valves usually result in abnormally low suction pressure.

8. Thermal Expansion Valve is Obstructed

Unless the expansion valve is properly protected by a strainer or filter, foreign matter may obstruct the valve port. If the obstruction is small, the resulting operation will be much the same as though the valve were undersized as described in 7 above. If the obstruction holds the valve open during shutdown, the operation will be as described in 2 and 3. An obstructed expansion valve is usually indicated by a partly warm evaporator.

9. Shortage of Refrigerant

A shortage of refrigerant will be initially indicated by bubbles in the sight glass. Frequently there will be a hissing or whistle at the expansion valve. The coil and suction line will be relatively warm while the suction pressure will be low due to little or no liquid being supplied to the evaporator if the shortage is severe.

10. Overcharge of Refrigerant

An overcharge of refrigerant will cause high head pressure. Liquid will back up in the condenser and decrease the amount of surface available for condensing and as a result the head pressure will rise. In extreme cases, it may rise to a point where high-pressure cut-out will stop the compressor. This may result in "short cycling", (compressor cycles too frequently).

11. Air in System

If air or other non-condensable gases are present in the system, they will tend to move toward and collect at the condenser. The head pressure will rise to a point above the pressure corresponding to the temperature at which the vapour is condensing. In extreme cases, the pressure may rise to a point where the high-pressure cut-out may stop the compressor.

12. Broken Valves in Compressor

Broken or leaky discharge valves in a compressor are generally indicated by the suction pressure rising rapidly as soon as the machine is stopped. If the suction pressure rises faster than 13 kPa per minute, it is an indication that the compressor discharge valves are not holding. Before the compressor is opened, however, it should be determined that the pressure rise is not due to other causes such as a leaky expansion valve.

13. Fault Diagnosis for Electronic Thermostat

Refer to the Electrical Schematic Drawing for the controller. As this is a fully sealed item it cannot be field checked for correct operation and should be returned to TRACS if suspected to be faulty. It is unlikely that the thermostat will fail due to internal causes and therefore external wiring should be checked prior to deeming if failed and especially when replacing with a new unit.

14. Wiring Check

In light of the above the following check can be performed to ensure wiring is correct and must be carried out prior to replacing a blown thermostat. Checks should be performed in OFF-LO-HI on the female supply plug to the thermostat from the loom.



FAULT DIAGNOSIS

DIAGNOSIS FOR ELECTRONIC THERMOSTATS

Test	Reason
Power present at P1.1 in LO-MED-HI (Note - P1.1 refers to terminal No. 1)	Ensures power supply to thermostat
Continuity between P1.5 and earth.	Ensures circuit to earth.
No continuity between P1.7 and earth	“
No power at P1.6 and P1.8.	Power on potentiometer (POT) control lead will blow thermostat.

15. Electronic Thermostat Fault Finding

COMPLIANT	POSSIBLE CAUSE	REMEDY
Continuously operates in cooling	Potentiometer control lead open circuit. Internal contacts welded closed	Repair lead. Check wiring, find fault and replace.
Continuously operates in heating. Heat illuminated on thermostat.	Temperature probe lead open circuit. Internal contacts welded closed.	Replace thermostat. Check wiring, find fault and replace.
Thermostat inactive	Circuit breaker tripped.	Check wiring, find fault and reset circuit breaker
Unit lacks capacity	Return air probe in de-ice probe location.	Place in air stream of return air.
Works in HEAT mode but not in COOL.	Probes overheated (+150o C)	Replace thermostat.

Fault Diagnosis – Pressuriser

NOTE: This section is written on the assumption that the service mechanic is a qualified trades person in refrigeration and air conditioning. They must have a good understanding of the systems operation prior to fault diagnosis and repairs (If in doubt please ask).

THE UNIT WILL NOT START OR IS PERFORMING POORLY:

1. Check main circuit breaker or power fuse supply. Make sure the motor is receiving the correct power supply & that it is maintained once the machine is running.
2. If the unit uses a motor with serviceable brushes. Check brush condition and for any dust build up in the brush holders.

POOR PERFORMANCE

1. Is the Primary filter serviceable. C
2. Check cabin sealing. Check to see if the door & window seal are serviceable. Ensure all boots & gaskets been refitted after the last service/repair.
3. Ensure the correct voltage motor is installed.
4. Fan wheel rotation. There are left & right-handed fan wheels. Ensure the correct fan wheel is installed.

DUST IN CABIN

1. Check all cabin seals and test to ensure positive cabin pressurisation is been achieved, and maintained at a minimum of 25Pa above ambient pressure.

* Do not handle until MSDS & all safety precautions have been read and understood. Use personal protective equipment as required.

Before use, carefully read the product label. Safe work practices are advised to avoid eye or skin contact and inhalation. Observe good personal hygiene, including washing hands before eating. Prohibit eating, drinking, and smoking in contaminated areas. Avoid inhalation. Mechanical extraction ventilation is recommended when the removal of atmospheric contaminants is required. Maintain dust / fume levels below the recommended exposure standard. For small amounts, absorb with sand, vermiculite or similar and dispose of at an approved landfill site.

WARNING

- For Professional Use Only – keep out of reach of children.
- Do not ignite near or around flammable materials.
- Use only in well-ventilated areas, outdoors, and/or with proper respiratory protection.
- Persons with respiratory sensitivity should avoid exposure to any smoke.
- Concentrated smoke may cause severe burns to the skin, eyes, or respiratory system.
- Improper use may result in sufficient inhalation of smoke to cause respiratory tract irritation and lung damage.
- Harmful if swallowed.

DANGER

Use only as directed. Do not handle until all safety precautions, including Safety Data Sheet, have been read and understood. The product contains hexachloroethane. Wear protective clothing. If exposed or concerned, get medical advice. Store in a cool, dry, secure location. KEEP OUT OF REACH OF CHILDREN. Dispose of contents/container per location regulations. When used as directed, exposure should be limited and usually poses no hazard because the hexachloroethane is consumed inside the tube as smoke is produced.

Directions: (Smoke Bomb)

1. Ensure other workers in close proximity are informed of use. Place on a non-combustible container, away from flammable materials.
2. Place at Blower intake, or upwind of target area, or near centre of space.
3. Orient "Smoke Issues Here" toward air stream, away from surfaces. Place candle on a flame / heat resistance plate – if not it will melt into the plastic surface.
4. Ensure smoke will not create any hazard where it is anticipated to go.
5. Ignite emitter inside the cabin using site approved device i.e., solder torch or 'lighter' and conduct smoke test.
6. Do not touch or hold smoke generator after ignition – item becomes very hot & remains hot after use.





Smoke Emitter Cabin Pressure Leak Test

1. The pressuriser system is switched on (TEST MODE).
2. Hold the smoke emitter angled down.
3. Ignite emitter using site approved ignitor i.e., solder torch or 'lighter'.
4. When the product ignites, remove the lighter.
5. If the product flames up, blow out the flame.
6. Place the emitter in a non-flammable container and place it inside the cabin at floor level and close the door/windows.
7. Observe smoke leaks to indicate worn-out or broken seal locations. Check leakage points outside the cabin.
8. Do not come into contact with or inhale smoke haze.
9. Wait until the smoke haze **completely** disperses before re-entering the cabin. Open door to allow sufficient ventilation of smoke prior to entering cabin.



SMOKE EMITTER CABIN PRESSURE LEAK TEST

Link to MSDS: [SMOKE GENERATOR TQ7621AT30S.pdf](#)



Personal Protective Equipment (PPE)

	Safety glasses must be worn at all times.
	Sturdy footwear with rubber soles must be worn.
	Respiratory protection devices may be required.
	Gloves may be worn.

Pre-operational Safety Checks

	Locate and ensure you are familiar with all machine operations and controls.
	Check work area and walkways to ensure no slip/trip hazards are present.
	Ensure the work area is clean and clear of any flammable material & fire extinguish device is present.

Operational Safety Checks

	Ensure the machine is correctly isolated / immobilized.
	Ensure other persons do not inhale smoke haze.
	Take care and do not place a lit emitter close to a flammable surface.

Ending Operations and Cleaning Up



	Leave the work area in a safe, clean, and tidy state.
---	---

Potential Hazards

	Falls
	Fumes
	Fire
	May cause cancer

Exposure is highly unlikely when the product is used as directed. Direct contact with the product does not occur.

Don't

	Do not use if an open flame is forbidden.
	Never leave the emitter [cabin test] unattended.

*This SWP does not necessarily cover all possible hazards associated with this equipment and should be used in conjunction with other references. It is designed as a guide to be used to compliment training and as a reminder to users prior to equipment use.

Commissioning Procedures

COMMISSIONING PROCEDURES – CABIN PRESSURISER

Follow each step of the installation guide that was supplied with the BreatheSafe kit.

Cabin sealing is an integral part of RS20 & ISO 23875; you must ensure that cabin seals are adequate for maintaining positive pressure. In addition, the site (end- user) must have the correct procedure(s) for servicing OPERATOR enclosure seals in a proactive manner rather than reactive. Items such as door and window seals must be in good working order or new seals FITTED before the BreatheSafe system installation.

Touch-screen cabin pressure display/controller Part# 200027:

***System Check Function:** enter the Settings menu option and select “System Check – Set Max.” The minimum BreatheSafe requirement for cabin sealing efficiency is 250 pascals; if this result is not met, it is essential to re-examine and find pressure leaks of the enclosure and apply new sealing measures.

Submission for commissioning procedure as per the diagram below:

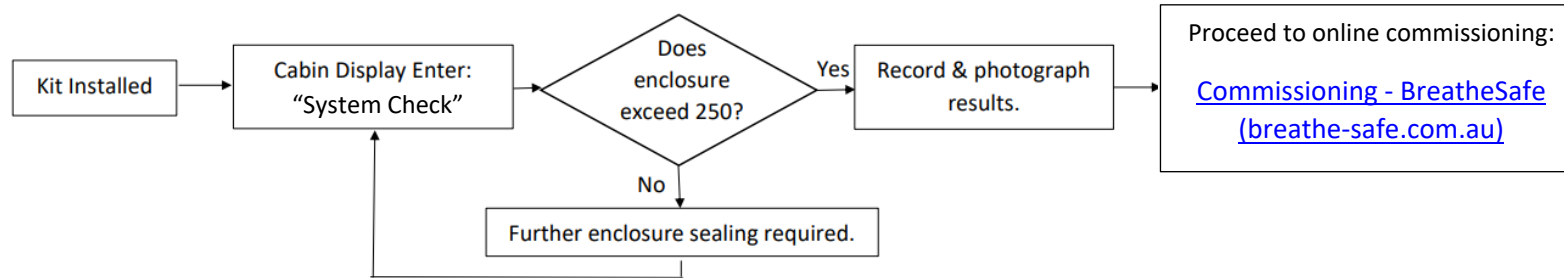

BreatheSafe
Part of **AireSafe**

Commissioning Certificate

Customer Details
Company: _____
Customer Email: _____
Customer PO Reference: _____
Job Reference No: _____
Location: Australia _____
Collaborator Name: _____

Date of Issue _____
Date of Installation/Commissioning _____

Installer/Commissioning Technician
Name: _____
From Company: _____
Company / Agent: _____
Installation Location: _____
Same as customer location:

Machine Details
Brand: CAT/TEREX
Type: Wheel Loader
Model: _____
Year No: _____
VIN/Serial No: _____
Machine Age: _____
BreatheSafe System
Pressuriser Model: TLK
Pressuriser Serial No: _____
Monitor Model: INPRESS TL
Monitor Serial No: _____
Fresh Air Filter P/N: _____
Return Air Filter P/N: _____
A/C Carbon Filter P/N: _____

Removed Parts/Filters
Fresh Air Filter P/N: _____
Return Air Filter P/N: _____

Commissioning and Calibration Results
Date of Test: _____
Max Pressure (Pa): _____
Pressure Setpoint (Pa): _____
Actual Pressure (Pa): _____
Motor Load (%): _____

Nonconform Time Cabin Results
Tested at A/C vent: _____
Tested in Breathing Zone: _____

Warning
Motor/Speed Motor - 3 years or 15,000 hours extended warranty

Installation Notes

The commissioning images required are:

- ID plate / Machine Serial Number / Asset Number or Call Sign
- INPRESS TL Pressuriser location
- HEPA Return Air Filter Location Option: Powered Return Air Filter
- Cabin Pressure Display Location – Including the “System Check” maximum cabin pressure result with motor output capacity %

Fill in the BreatheSafe Service Tag with the following details:

- Machine Serial Number and Installers details
- Date installed and System Check result (max cabin pressure)
- The set cabin pressure with actual pressure and motor percentage output
- Verify the 250-pascal threshold was achieved = pass OR not achieved = fail**

BreatheSafe
Part of **AireSafe**

AIR CONDITIONING FAN MUST BE TURNED TO MEDIUM SPEED TO CIRCULATE AIR & MAINTAIN CO₂ LEVELS.

MACHINE SN: _____ BREATHESAFE CONTROLLER SN: _____

DATE INSTALLED: _____ MACHINE HOURS: _____

AUTO PRE-SET PRESSURE (Pa): _____ MAX CABIN PRESSURE (Pa): _____

NOTES (FILTER PART NUMBERS): _____

1 2 3 4 5 6 7 8 9 10 11 12 13 14 15 16 17 18 19 20 21 22 23 24 25 26 27 28 29 30 31

JAN FEB MAR APR MAY JUN JUL AUG SEP OCT NOV DEC

2023 2024 2025 2026 2027 2028

Technical Support Phone: 1300 667 597 | www.breathe-safe.com

Please upload machine and installation details in conjunction with the required images. A Commissioning Certificate will be sent to the email address you nominate. **Extended warranty for (RS20 & ISO 23875) BreatheSafe Systems is only applicable to operator enclosures meeting this requirement.

BREATHESAFE SYSTEM TROUBLE SHOOTING GUIDE *TOUCH CONTROL		
FAULT	POSSIBLE CAUSE	SOLUTION
*ERR error code	Poor sensor connection	Remove & refit pod connection cable
	Corrupted coding	Contact support for default reset pin
*Check filter alarm	Service hour timeout	Access Check Runtime menu - reset hours via 7597 code
Temperature / CO2 error	Sensor not connected	Fit sensor or disable via site access CO2 & or temperature menu
Pressuriser running at full speed/noisy	Filter blocked	Service filter
	Door or window open	Ensure doors & windows securely shut
	Cabin sealing capacity not adequate	Perform pressure test procedure & seal leak points as required
	Sense pipe blocked	Ensure clear & not bent
	Internal sensor damaged	Replace controller **No need to change setpoint
Filter blocking quickly	Defective cabin sealing	Perform pressure test procedure & seal leak points as required
	Pre-cleaner failed	Check operation & replace if necessary
Display blank	Poor power supply	Check mains supply fuse & correct voltage
		Check voltage & 20AMP supply/connections at pin 1 @ monitor
		Check earth continuity at controller pin 12
	Failed controller	Replace monitor
Controller showing 0.0 pressure	Fresh air filter blocked	Check filter condition & replace if required.
Low pressure alarm	Door or window open	Ensure doors & windows securely shut
	Cabin sealing capacity not adequate	Perform pressure test procedure & rectify cab sealing
	Pressuriser not operating	Ensure correct voltage 12v or 24v to pressuriser motor pin A
		Check 1.6V - 10V present at motor Pin C
		Check 20A Supply fuse
		Check earth continuity Pin B
Pressure sense tube blocked	Unplug at monitor & ensure clear flow to external of cabin	
	Ensure pressure tube fitted correct port A	
	**No need to change setpoint	
Pressuriser not working	Poor power supply	Check 20A mains fuse & correct voltage
		Ensure adequate wire size & no voltage drop
		Ensure correct voltage 12v or 24v to pressuriser motor pin A
		Check 1.6V - 10V present at motor Pin C
	Poor earth	Check earth continuity @ motor pin B
Motor faulty	Replace TL4M	
Access Codes:	Site Access: 7597	Contact Support for Factory Setup Pin

User Settings Instructions

ENTER SET UP MODE

Start-Up Screen > Main Screen > Settings Button > Settings Screen > Site Access Button > Insert Pin > Site Menu

To enter the Setup mode, press the SETTING button.

Then enter SITE ACCESS MENU. Type in 4-number pin and press ENTER.

Insert Pin = 7597

Enter Pin

1	2	3
4	5	6
7	8	9
CLEAR	0	ENTER

7597

SET UP PARAMETERS

Placing the BreatheSafe 200027 unit into Setup mode allows the adjustment of the following parameters:

- Time (hours/minutes/seconds)
- Date (day/month/year)
- Pressure alarm setpoint
- Preferred cabin pressure
- Alarm delay/ intervals of alarm
- Calibration and system settings
- Resetting of the data logging
- Service reminders interval gap
- Reset current runtime between services
- CO2 settings and alarms

USER SETTINGS INSTRUCTIONS

Settings

SYSTEM CHECK	VIEW GRAPH
EVENT LOG	SITE ACCESS MENU

BreatheSafe

Settings Page 1

STARTUP OPTIONS	DOOR WINDOW SETTING	PRESSURE SETPOINT
CHECK RUNTIME	DATE / TIME	CO2 SETTING

BreatheSafe

Settings Page 2

ALARM MUTE RESET	ZERO SENSOR	TEMP SETTING
BUZZER SETTINGS	LOG SETTINGS	FACTORY SETUP

BreatheSafe

PRESSURE SETPOINT

The pressure setpoint changes the pressure that the cabin will be maintained. INPRESS TS maintains the pre-set pressure within the cabin compared to outside.

Enter Setup mode and select ADJUST SETPOINT button. Then, use the onscreen UP and DOWN buttons to change the corresponding fields.

1 Main dashboard showing Cabin Pressure 50Pa, CO2 Level 200 PPM, and Temperature 20°C.

2 Settings menu with options: SYSTEM CHECK, VIEW GRAPH, EVENT LOG, and SITE ACCESS MENU.

3 Enter Pin screen with PIN 7597.

4 Settings Page 1 with options: STARTUP OPTIONS, DOOR WINDOW SETTING, PRESSURE SETPOINT, CHECK RUNTIME, DATE / TIME, and CO2 SETTING.

5 Pressure Settings screen with fields: Alarm Set Point (20), Pressure Set Point (50), and Pressure Alarm Delay (5 mins).

PRESSURE ALARM SETTING

USER SETTINGS INSTRUCTIONS

The mining industry benchmark for cabin pressure is 50 pascals and low-pressure is set at 20 pascals.

After a delay the alarm will activate if cabin pressure remains below the pre-set value. Enter Setup mode and select ADJUST SETPOINT button. Then, use the onscreen UP and DOWN buttons to change the corresponding fields.

1 Main dashboard showing Cabin Pressure 50Pa, CO2 Level 200 PPM, and Temperature 20°C.

2 Settings menu with options: SYSTEM CHECK, VIEW GRAPH, EVENT LOG, and SITE ACCESS MENU.

3 Enter Pin screen with PIN 7597.

4 Settings Page 1 with options: STARTUP OPTIONS, DOOR WINDOW SETTING, PRESSURE SETPOINT, CHECK RUNTIME, DATE / TIME, and CO2 SETTING.

5 Pressure Settings screen with fields: Alarm Set Point (20), Pressure Set Point (50), and Pressure Alarm Delay (5 mins).

SERVICE INTERVAL

Use the onscreen UP and DOWN buttons to change the service interval setpoint.

To reset the current runtime to zero, press the RESET CURRENT RUNTIME button and enter the site access pin.

1 Home screen showing Cabin Pressure (50Pa), CO2 Level (200 PPM), and Temperature (20°C).

2 Settings menu with options: SYSTEM CHECK, VIEW GRAPH, EVENT LOG, and SITE ACCESS MENU.

3 Enter Pin screen with a numeric keypad and the pin 7597 entered.

4 Settings Page 1 menu with options: STARTUP OPTIONS, DOOR WINDOW SETTING, PRESSURE SETPOINT, CHECK RUNTIME, DATE / TIME, and CO2 SETTING.

5 Pressure Settings screen showing PRESSURE UNITS = Pascals, CURRENT RUNTIME (700), and SET SERVICE INTERVAL (1000).

DATE & TIME SETTINGS

Change the recorded date displayed and measured by the INPRESS TS.

USER SETTINGS INSTRUCTIONS

1 Home screen showing Cabin Pressure (50Pa), CO2 Level (200 PPM), and Temperature (20°C).

2 Settings menu with options: SYSTEM CHECK, VIEW GRAPH, EVENT LOG, and SITE ACCESS MENU.

3 Enter Pin screen with a numeric keypad and the pin 7597 entered.

4 Settings Page 1 menu with options: STARTUP OPTIONS, DOOR WINDOW SETTING, PRESSURE SETPOINT, CHECK RUNTIME, DATE / TIME, and CO2 SETTING.

5 Date/Time Settings screen showing PRESSURE UNITS = Pascals and date/time selection (4 : 10 22 / 04 / 2023).

PRESSURE ALARM BUZZER SETTING

To disable the buzzer, toggle through to the ENABLED and DISABLED buttons.

1 Main dashboard showing Cabin Pressure (50Pa), CO2 Level (200PPM), and Temperature (20°C).

2 Settings menu with 'SITE ACCESS MENU' highlighted.

3 Enter Pin screen with '7597' entered.

4 Settings Page 1 with 'PRESSURE SETPOINT' highlighted.

5 Settings Page 2 with 'BUZZER SETTINGS' highlighted.

6 Alarm Buzzer Settings screen with 'ENABLED' buttons for Pressure, CO2, and Temperature buzzers.

CALIBRATE ZERO SENSOR

Over long runtime, the 200027 may need recalibration. This screen allows the sensor to be recalibrated if more than 5 Pascals are out. To recalibrate, open windows and doors, turn off air conditioning, and any other device that may alter cabin pressure. Then, press the AUTO ZERO SENSOR button and leave the cabin while measuring. This process will reset the Zero Pressure.

ALARM BUZZER SETTINGS

1 Main dashboard showing Cabin Pressure (50Pa), CO2 Level (200PPM), and Temperature (20°C).

2 Settings menu with 'SITE ACCESS MENU' highlighted.

3 Enter Pin screen with '7597' entered.

4 Settings Page 1 with 'PRESSURE SETPOINT' highlighted.

5 Settings Page 2 with 'ZERO SENSOR' highlighted.

6 Zero Sensor Adjustment screen with 'AUTO ZERO SENSOR' button.

CO2 MODULE ENABLE/DISABLE

Enable or disable to CO2 module used for measuring CO2 levels within the cabin.

CO2 PRIMARY ALARM POINT

The first alarm will sound when CO2 levels inside the enclosure reach this point.

CO2 SETTINGS

1

2

3

4

5

1

2

3

4

5

CO2 ALARM DELAY

After CO2 (concentration in ppm) within the cabin reaches the 1000 ppm setpoint, the alarm will sound after this designated amount of time. The Alarm Delay adjusts the time between the INPRESS TS measuring CO2 concentration and sounding the alarm. Use the onscreen ADJUST buttons to change the corresponding fields. For example, press to toggle through Disabled / 1 – 10 minutes.

1 Main dashboard showing CO2 Level at 200 PPM.

2 Settings menu with 'SITE ACCESS MENU' highlighted.

3 'Enter Pin' screen with PIN 7597.

4 'Settings Page 1' with 'CO2 SETTING' highlighted.

5 'CO2 Sensor Alarm Setting' screen showing 'CO2 ALARM DELAY SETTING' at 2 Min.

CO2 CRITICAL ALARM MUTE RESET

The critical alarm is set at 2500 PPM and cannot be changed. The mute delay, however, can be configured.

CO2 SETTINGS

1 Main dashboard showing CO2 Level at 200 PPM.

2 Settings menu with 'SITE ACCESS MENU' highlighted.

3 'Enter Pin' screen with PIN 7597.

4 'Settings Page 1' with 'CO2 SETTING' highlighted.

5 'CO2 Sensor Alarm Setting' screen showing 'CO2 CRITICAL ALARM SETPOINT' at 2500 PPM.

6 'Critical Alarm Mute Timeout Adjustment' screen showing 'SET MUTE TIMEOUT MINUTES' at 10 Mins.

Data Download – Setting up RS232 Connection



- 1 Plug the RS232/USB adaptor into a free USB port on your computer.
- 2 Open up TeraTerm software.
(*TeraTerm* is an open-source software tool and easily accessible via online search)
- 3 Use the following settings in TeraTerm: Serial and choose the correct port connection.

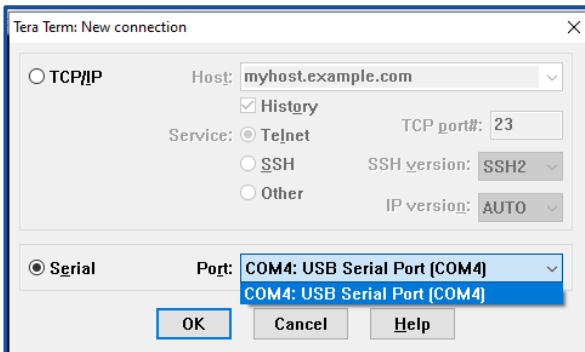

Hint:
Click on the COMxx Port with the “USB serial Port” connection from the drop-down menu.

Example:
COM 4
This connection may be different on your computer.

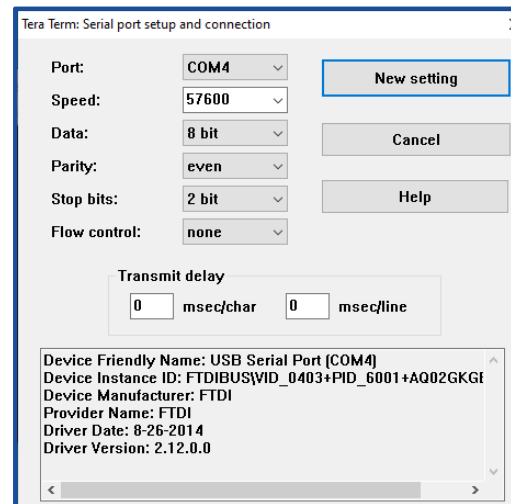
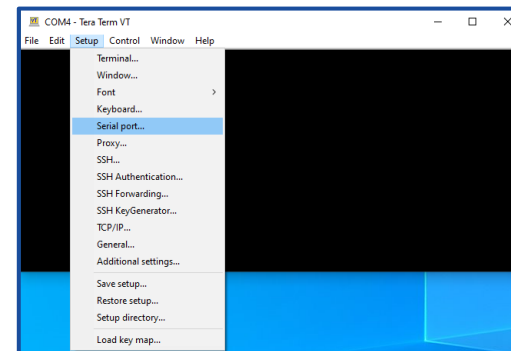
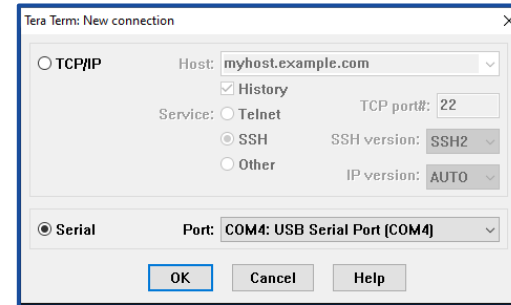

DATA DOWNLOAD

- 4 Click OK once the correct communication port has been identified.
- 5 Go to SETUP and click on Serial Port.
- 6 Change the COM ports to the following configuration:

Baud

Rate: 57600 Data: 8 bit

Parity: EVEN

Stop: 2 bit

Flow Control: NONE

DATA DOWNLOAD

Data Download – Setting up RS232 Connection

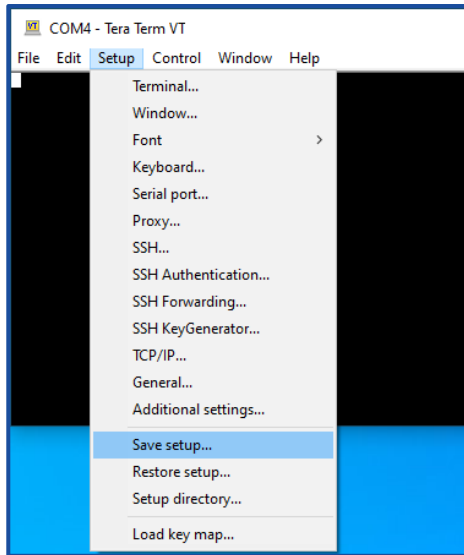

- 7 If required, you may choose to save the COM port settings. Go to Settings and click save the setup.

Hint: From the drop-down menu, click on the Save Setup.

Name the file and save it.

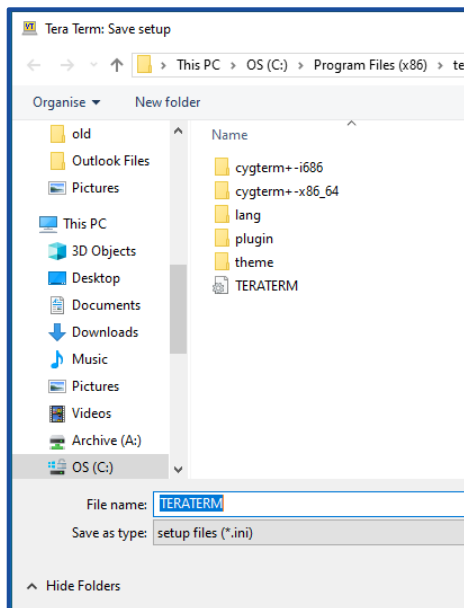

- 8 The next time a download is required, you may restore the setup, and the required COM PORT settings will be loaded, ready to download the data file from the 200027 unit.

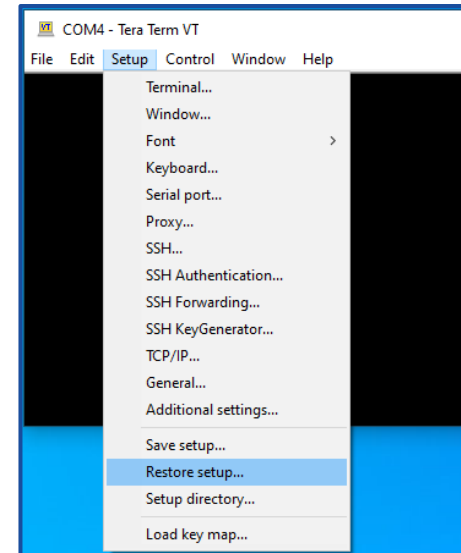

- 9 From the drop-down menu, click on Restore setup.

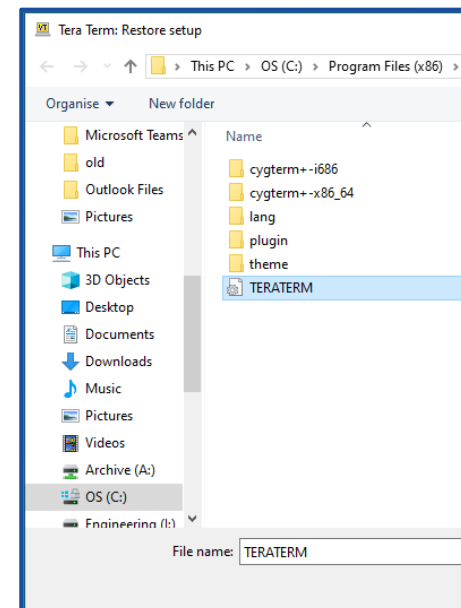

- 10 Choose the file name you have already saved.

INPRESS Controller Set Up

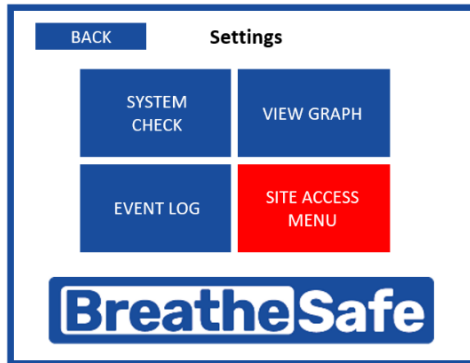

1. Press 'SITE ACCESS MENU'.

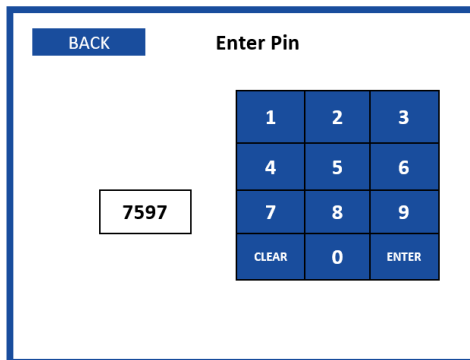

2. Enter the access pin '7597'.

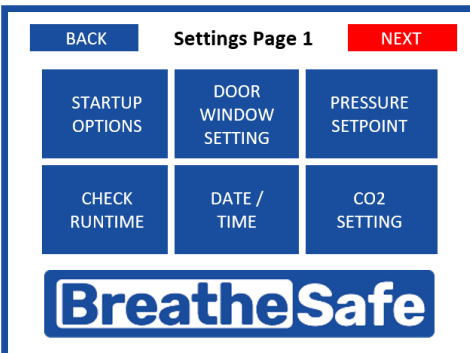

3. Press 'NEXT'.

CONTROLLER SET UP

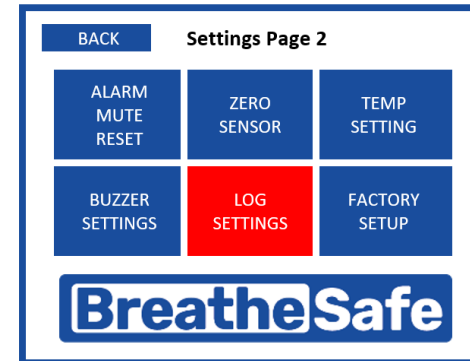

4. Press 'LOG SETTINGS'.

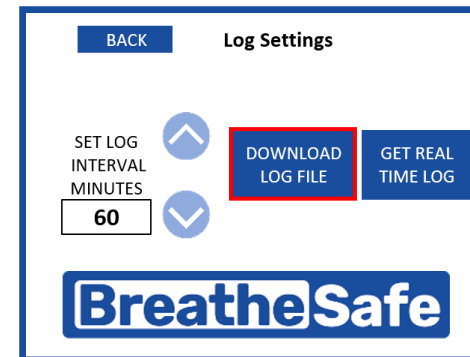

5. Press 'DOWNLOAD LOG FILE'.

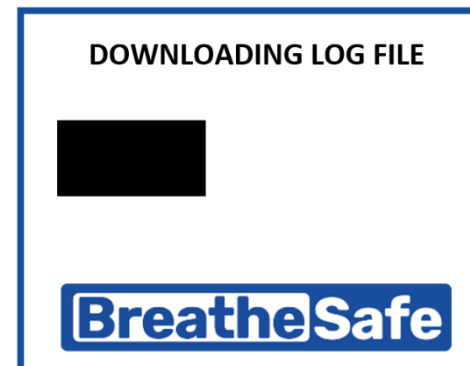

6. Data is now downloading from controller to terminal open on the computer (TeraTerm in this example).

DATA DOWNLOAD

Data Download – Copying Contents from Terminal to Spreadsheet

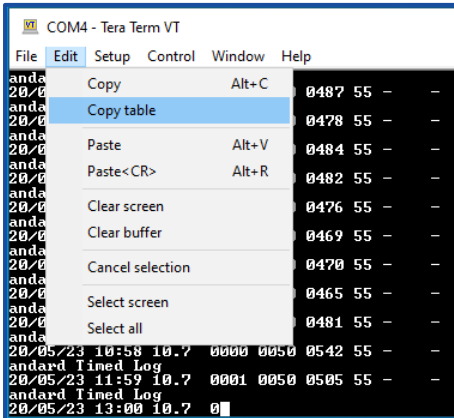
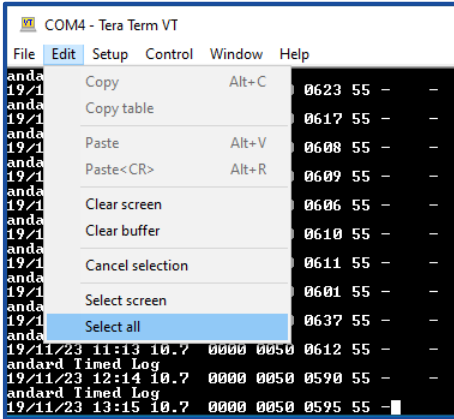

	A	B	C	D	E	F
	DATE	TIME	MOTOR (VOLT) OUTPUT	CABIN PRESSURE PA	CABIN PRESET PA	CO2 Sensor
2	12/11/2023	16:43	2.1	50	50	600
3	12/11/2023	17:44	2.1	50	50	596
4	12/11/2023	18:46	2.1	51	50	601
5	12/11/2023	19:47	2.1	50	50	603
6	12/11/2023	20:48	2.1	50	50	595
7	12/11/2023	21:50	2.1	50	50	593
8	12/11/2023	22:51	2.1	50	50	591
9	12/11/2023	23:52	2.1	50	50	588
10	13/11/2023	0:54	2.1	51	50	595
11	13/11/2023	1:55	2.1	50	50	582
12	13/11/2023	2:56	2.1	50	50	587
13	13/11/2023	3:58	2.1	51	50	593
14	13/11/2023	4:59	2.1	50	50	598
15	13/11/2023	6:00	2.1	51	50	742
16	13/11/2023	7:02	2.1	51	50	767

12 From the drop-down menu, click on the Edit menu function.

13 Press “Select All”.

14 Select “Copy table”.

15 Open a blank excel document and click on the page. Then, right-click to paste the copied table.

16 Fields are:

Date, time, motor (volts) output (e.g. 5.5 = 55%), cabin pressure (Pa), cabin pressure pre-set (Pa), CO2 sensor.

Excel Data Instructions – Unformatted

Open an Excel sheet and select the first cell A-1. Next, press and hold down the CTRL button on your keyboard and then press the letter V on the keyboard.

This procedure will paste the copied data onto that Excel sheet. Once that data has been pasted onto the Excel sheet, click on ‘DATA’ on the pull-down menu, followed by ‘Text to Columns’. Next, select ‘Delimited’ on the newly opened window and click on Next.

Only select the ‘Comma’ button in the next window and then click ‘Finish’. Then, the Excel fields will update such that each piece of data is placed in the correct columns.

The data is now ready for archiving.

Data Logging Formats

BU No: xxxxxx (the device number unique to each unit and used for identification – format = 000000)

Time: [09:25]

Date: [25/07/12]

Pressure: 32 (Pascals) as an example.

Alarm Type	
0	= No alarm
1	= Low-pressure alarm
2	= Window open
3	= Door open

INPRESS TL WARRANTY

Express Warranty

All BreatheSafe products carry a warranty against defects in materials or workmanship, provided the defects are not from factors outside of BreatheSafe's control (including neglect, lack of maintenance, improper installation or operation, unauthorized servicing repair, etc.). BreatheSafe will replace goods defected in material or workmanship at our Queensland factory or designated branch*. All parts deemed as failed or faulty must be returned to BreatheSafe for evaluation unless otherwise stated in writing.

Note- Systems must be installed and commissioned as per BreatheSafe installation and commissioning instructions. Once commissioned, the online commissioning sheet must be filled in, extending the components warranty as below. In addition, the system must be serviced and maintained correctly and by trained and qualified personnel. This requisite includes BreatheSafe technicians, qualified automotive air-conditioning technicians, or qualified auto electricians.

Warranty period – Standard

- 1 year or 10,000 hours (whichever occurs first).
- Controllers – 1 year no extended warranty option.
- Warranty Period Extension when commissioning documents are registered online within 28 days of installation
- Extended warranty** only offered if commissioning maximum pressure test reaches at least 250Pa.
- Brushless motor fixed speed two years, or 10,000 hours (whichever occurs first).
- Variable speed brushless motor 15,000 hours, or 3 years** (whichever occurs first).

Must be supplied with a variable speed pressure controller, data download required for 3-year warranty option. Link to online Commissioning and Extended Warranty Registration form <https://www.breathe-safe.com.au/commission/>

What is not covered under Express Warranty?

- Failures are due to incorrect application.
- Damage resulting from neglect, misuse, lack of maintenance, improper installation, or operation, inappropriate or abnormal use, accidental or unauthorized servicing repair.
- Failures are due to parts not being sold or approved by BreatheSafe.
- Failures arising from any other cause that is not directly related to a defect in material or workmanship.

This Express Warranty is VOID if the product is altered, modified, or used in the manner it was not designed for, also including unauthorized repairs, or using maintenance and repair parts other than those supplied by BreatheSafe.

BreatheSafe responsibilities

If there is a defect in material or workmanship not caused by the excluded failures during the warranty period, BreatheSafe will either replace the defective goods at our Queensland factory, or designated branch. *

Alternatively, BreatheSafe may elect to provide new replacement parts, BreatheSafe approved repair parts or assembled components needed to repair the defect. BreatheSafe reserves the right to provide a refund of the purchase price in lieu of replacement or repair at BreatheSafe's discretion. The replacement or repaired product will be sent to you freight prepaid by the customer or made available for pick-up on site.

Users Responsibilities

The customer should ensure that the system is maintained according to BreatheSafe service requirements and only authorized parts must be used to service and maintain BreatheSafe systems. In the event of a suspected warranty claim, BreatheSafe should be contacted in the first instance to arrange the repair or to assist with diagnosis. Claims should be made within one week of the repair.

After contacting BreatheSafe, you may be required to deliver or send the parts to BreatheSafe's Queensland factory or designated branch. * Link to online Warranty claim form <https://www.breathe-safe.com.au/warranty/>

Exclusion and Limitations on Damages and Remedies

This warranty is provided in lieu of all other warranties, written or oral, whether expressed by affirmation, promise, description, drawing, model, or sample. To the extent allowed by law, all warranties other than this warranty, whether express or implied, including implied warranties of fitness for a particular purpose, are disclaimed. The maximum liability of BreatheSafe under this warranty shall not exceed the original purchase price of the product. Interference with the equipment by or abuse, or by operating the equipment at ambient temperatures or with electrical power characteristics outside the ranges indicated in our specification shall be excluded from this warranty, as shall consequential damages.

Excluded from any express warranty are costs incurred in relation to service outside our factory our designated service branch, including traveling time, waiting time, transport costs, mechanical and overtime payments required. As per Australian Consumer Law: You are entitled to choose a refund or replacement for major failures with goods. If a failure with the goods or service does not amount to a major failure, you are entitled to have the failure rectified in a reasonable time. If this is not done, you are entitled to a refund for the goods and to cancel the contract for the service and obtain a refund of any unused portion. You are also entitled to be compensated for any other reasonably foreseeable loss or damage from a failure in the goods or service.

***This express warranty gives you specific legal rights, and you may also have other rights that vary from country to country.**