

Kit Part Number: Provisional

Breathe Safe

Part of **Aire Safe**

Parts and Service Manual

TOYOTA

8FD80N FORKLIFT

HEPA H14 Variable Speed Pressuriser | INPRESS Cabin Display | HEPA Return Air Filter
+ Activated Carbon



+61 7 3276 7833



www.breathe-safe.com.au



sales@breathe-safe.com



62 Mica Street, Carole Park, 4300, QLD

Controlled Document: M0435

Issue Date: 16/04/24

Revision: 1

INSTALLATION

CONTENTS

- Installation 1
- Safety..... 2
- Critical Parts & Maintenance
Schedule 3
- Operator Guide 4
- Specifications - Pressuriser 5
- Parts List 6-11
- Technical Details 12-16
- User Settings Instructions 17-23
- Warranty..... 24

INSTALLATION OVERVIEW

Manufacturer	Toyota
Type	Forklift
Model	8FD80N
Cabin Pressure Max	
Set Auto Cabin Pressure	



HEPA H14 Variable Speed Pressuriser



INPRESS Cabin Display with Data Recorder



HEPA Return Air Filter

SAFETY

WARNING

THE PRESSURISATION SYSTEM DESCRIBED IN THIS MANUAL HAS THE FOLLOWING AREAS WHICH MAY BE DANGEROUS IF NOT TREATED WITH GREAT CARE.

QUALIFIED STAFF MUST WEAR THE CORRECT PERSONAL PROTECTIVE EQUIPMENT WHEN CLEANING AND SERVICING THIS UNIT DUE TO DUST AND FIBRES WHICH MAY BE CAUGHT BY THE STAGES OF AIR FILTRATION DURING NORMAL UNIT OPERATION.

THE ELECTRICAL POWER SYSTEM IS SUPPLIED BY 12V DC OR 24V DC AND NO WORK SHOULD BE CARRIED OUT ON THE PRESSURISER SYSTEM WITHOUT THE CORRECT SAFE WORK PROCEDURES AND ELECTRICAL SAFETY MEASURES BEING TAKEN, AND ALL RELEVANT CIRCUIT BREAKER OPENED TO ISOLATE THE CIRCUIT.

THE AIR FILTRATION SYSTEM MAY HAVE SEVERAL TYPES OF HIGH-SPEED ROTATING EQUIPMENT INSTALLED WITH VERY SHARP EDGES. ENSURE ALL SAFETY GUARD ARE IN PLACE WHILE THE SYSTEM IS RUNNING.

Please be aware that HEPA filters cannot be cleaned and must be replaced at the end of their lifecycle or if filter media has been damaged.



Hard hat



Eye protection



Dust mask



Ear protection



Protective clothing

Particulate Behaviour

This is the length of time it takes for a particle to drop from a height of 1.5m in **STILL** air.



Warehouses and workshops do not have still air, so hazardous airborne particulates may remain in air for longer, increasing chance for workers to breathe in dust. Ensure PPE is worn when installing this system.



CRITICAL PARTS & MAINTENANCE SCHEDULE

Maintenance Schedule

The following tables show our suggested maintenance schedule for all units. Please note that site conditions may alter this.

Excludes high corrosion environments.

Data download is required to claim the 3-year warranty on Brushless Blower Motor.

Inspect every 500 Hours and replace when filter is full*

Component / System	Action Required
Turbo Pre-cleaner	Check operation of the Turbo Pre-Cleaner.
Pressuriser Blower	Ensure blower is operational.
HEPA Primary Filter p/n: 500000	Inspect filter capacity indicator. Replace HEPA filter when 80% or greater. Vacuum out housing before replacing the filter elements.
HEPA Return Air Filter P/N: 500016	Vacuum inside cabin floor before replacing filter.
Filter Frame Assembly, Mounts, Seals and Filter Housing	Check door seals, all bolts, screws, and all mounts are secure. Check the filter canister & ensure it is correctly fitted. Check latches are operational and in good order. Replace / Re-tension fixtures and fittings required.

15,000 Hours / 36 months*

Component / System	Action Required
500 Hour Inspection	All 500-hour inspection actions.
Pressuriser's Blower 200003	Replace BRUSHLESS Pressuriser blower.

Critical Parts				
Item	Part Number	Qty.	Description	Service Interval
1	500000	1	Fresh Air HEPA H14 Filter (Tested as per EN1822)	1000* Hours (>80% fan capacity)
2	500016	1	HEPA Return Air Filter	500* Hours
3	200003	1	Brushless Blower Motor – 12V	15,000 Hours
4	-	1	BreatheSafe Digital Display	
5	500068	1	Filter Activated Carbon	

*Filter service hours are subject to cab sealing efficiency, site conditions and correct system use.

OPERATOR GUIDE

OPERATORS CHECKLIST

PRE-START

- | | |
|----|---|
| 1. | Visually inspect the BreatheSafe system for any damage. |
| 2. | Visually inspect the cabin for any damage to doors, windows, seals. |
| 3. | Please remove dust & debris from shoes and clothes before entering the cabin. |
| 4. | Ensure door(s) and windows are closed correctly. |
| 5. | Start engine and turn HVAC on to speed 2 (medium speed). |
| 6. | After fixed speed delay, the BreatheSafe display will show 50 Pascals or pre-set value. |

The system is working correctly when the pascal value is green.

>> There is no further action required <<

NORMAL OPERATING CONDITION

Cab Air Conditioning

BreatheSafe recommends OEM air conditioning fan is set at mid speed or greater to circulate air around the breathing zone and minimise CO₂.

Acceptable operating range for BreatheSafe fan 10-80%. >80% recommend maintenance.

Specifications High-Capacity HEPA Pressuriser

Blower	: Brushless Blower P/N 200003.
Protection	: Locked Rotor Protection (Sub Zero Environments) Under Voltage, Under/Over Current & Over Temperature.
Voltage	: 12VDC.
Current Draw	: 11 amps (peak). *Note: Motor has slow start to stop excessive in-rush current.
Air Flow	: Up to 30-300 m ³ /h or 50-215 CFM.
Pre-cleaner	: Integrated VLR (Very Low Restriction). Turbo Pre-Cleaner.
Filter Element	: BreatheSafe HEPA Primary Filter (H14=99.99% MPPS) TESTED AS PER EN1822 – P/N 500000.
Plugs & Fittings	: Mining Spec. Deutsch electrical plugs as standard.
Construction	: High strength composite construction.
Serviceability	: Easy access HEPA filter with twist-lock (TL) dust cap single assembly.
Mounting	: Heavy Duty adjustable mounting brackets.
Design	: Fully designed in SolidWorks 3D CAD & Ansys Engineering Simulation Software.
FEA Testing	: Critical components FEA (Finite Element Analyst) tested in Solid Works Simulation.
CFD Testing	: CFD (Computational Fluid Dynamics) simulations in Flow Works to ensure optimum air flow through the system.

SPECIFICATIONS HIGH-CAPACITY HEPA PRESSURISER

List of Abbreviations	
DH	Dual HEPA
DHPR	Dual HEPA Powered Recirculation
DHAC	Dual HEPA Activated Carbon
DHACPR	Dual HEPA Activated Carbon Powered Recirculation
CPM	Cabin Pressure Monitor
CPU	Central Processing Unit
DB	Decibel Sensor
DPM	Diesel Particulate Matter
GAS	Gas Sensor
HEPA	High-Efficiency Particulate Air Filter
HPAFU	High Pressure Air Filtration Unit
HRAF	HEPA Return Air Filter
HVAC	Heating Ventilation and Air Conditioning
MAF	Mass Air Flow
OEM	Original Equipment Manufacturer
PM	Particulate Mass
RH	Relative Humidity
TEMP	Temperature
TS	Touch screen
UI	User Interface
VMS	Vehicle Monitoring System
VS	Vibration Sensor
OGSP	OnGuard Sensor Pod
CO2s	CO2 Sensor INPRESS TS

Item No.	Qty.	Description	Part No.
1	1	Pre-cleaner Hood & Rotor Assy	200004
2	4	Pre-cleaner Injector Ring	200005
3	1	TL Fan Blade (inc. in #7)	200006
4	1	TL Nose Cone / Pre-cleaner	200007
5	1	TL Motor Housing	200008
6	1	TL Filter Housing	200009
7	1	12v DC Brushless VSD Motor & TL Fan Blade	200003
8	1	O Ring Seal Kit 2 Parts	200010
9	1	Included in 8	200011
10	1	Wiring Sleeve	200012
11	1	HEPA H14 Filter	500000
12	3	M6 Nyloc Nut	300218 (M6NYL)
13	3	M6 x 55mm Hex Bolt	300982 (M655B)
14	4	M8 x 190 Hex Bolt	301136 (M8190B)
15	8	M8 x 22mm O/D HD Washer	300230 (M8222HTW)
16	4	M8 Nyloc Nut	300249 (M8NYL)
17	5	M4 x 75mm Pan Head Phillips Screw	300162 (M475PBH)

PARTS LIST – 12V DC PRESSURISER UNIT

PRESSURISER ASSEMBLY No: 200001

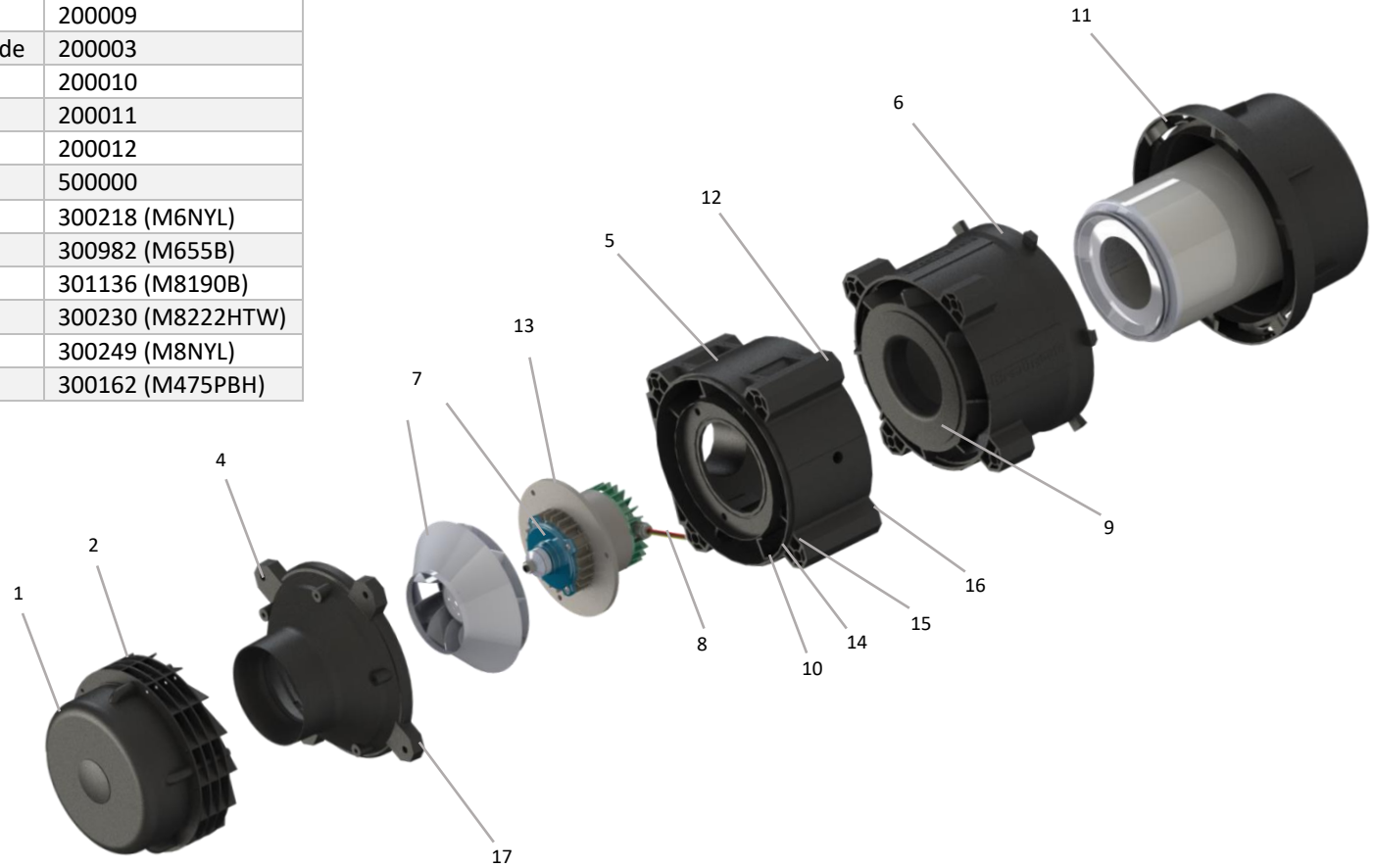

Item No.	Part No.	Rev	Description	Qty	Colour	Group
1	100254A01	0	Pressuriser Module	1	(Per Assy)	Module

PARTS LIST GA

COMPLETE ASSEMBLY No: **PROVISIONAL**

Kit Part Number: PROVISIONAL

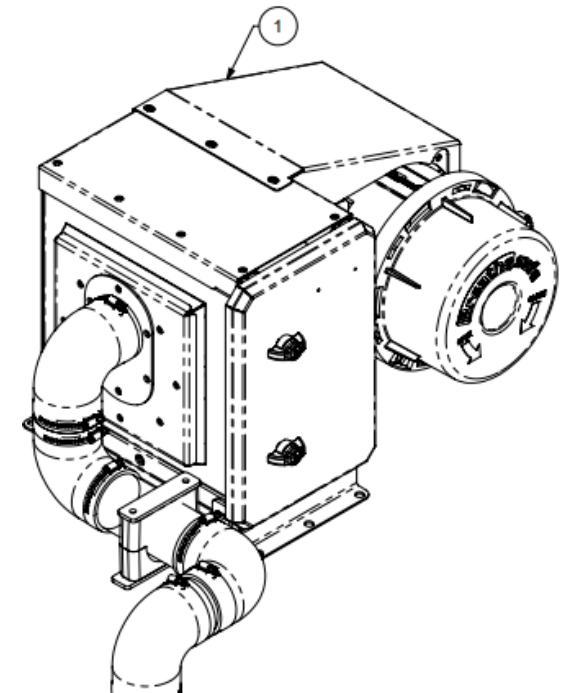

Item No.	Part No.	Rev	Description	Qty	Material	Thickness	Colour	Category
1	100254-A921	0	MK3 Mount	1	Mild Steel	3	Satin Black MX88-124	Part
2	TLM4	5	INPRESS TL Rain Cover & TL M	1	S/S	-	-	-
3	250502	[*]	MK3 Base Case 316SS	1	-	-	(Per Assy)	Stock Item
4	ST100510	[*]	MK3 SO2 Adj Outlet Spigot	1	S/S 304 N4	1.6	-	Stock Item
5	ST100511	[*]	MK3 SO2 Asj Outlet Plate	1	S/S 304 N4	1.6	-	Stock Item
6	200001	[*]	TL2 12V DC Unit	1	-	-	-	-

PARTS LIST – PRESSURISER MODULE

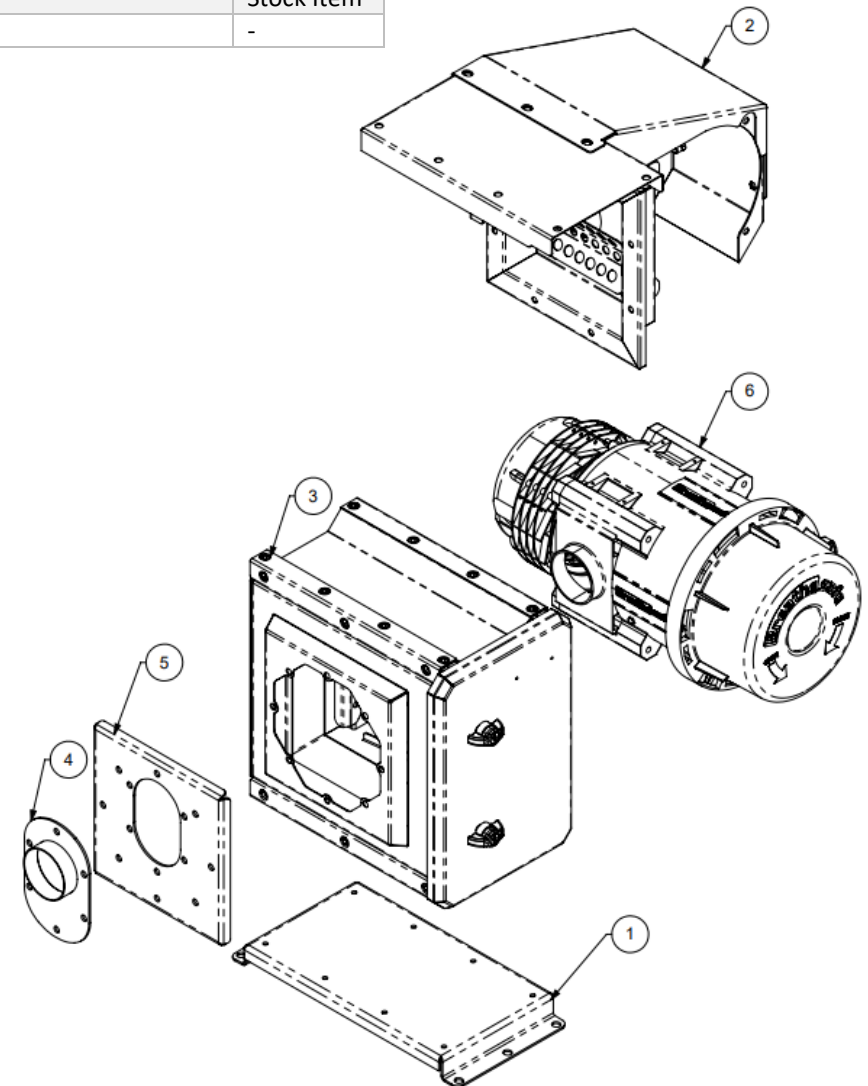

Item No.	Part No.	Rev	Description	Qty	Material	Thickness	Colour	Category
1	500016	[*]	HEPA Return Air Filter	1	-	-	-	Stock Item

PARTS LIST – RETURN AIR MODULE



Item No.	Part No.	Rev	Description	Qty	Material	Thickness	Colour	Category
1	TQUCPM INPRESS	[*]	Monitor	1	-	-	-	Stock Item
2	TQ657005	-	5 Amp Fuse – Controller	1	-	-	-	-
3	TQ657020	-	20 Amp Fuse – Motor	1	-	-	-	-

PARTS LIST - INPRESS



NOTE:

The INPRESS Cabin Pressure Monitor can be installed independently to display and record cabin pressure. This is a cost-effective method for fitting a cabin pressure display including capability to record & download data.

Please note that positive AIR pressure inside the cabin does not mean overall safety without SUBMICRON or high-efficiency particulate air (HEPA) filtration pressurisation.

Carbon Filter Carrier Removal

1. Ensure all relevant circuit breakers are open and the electrical circuit is isolated.
2. Unlock & open the door (Fig 1)
3. Uncouple both filter latches (Fig 2)
4. Pull the filter in the opposite direction off the air flow arrows, until clear (Fig 3)
5. Full the filter towards you and remove (Fig 3)
6. Clean the filter housing of all debris.
7. To replace the filter, assemble the components in reverse order.

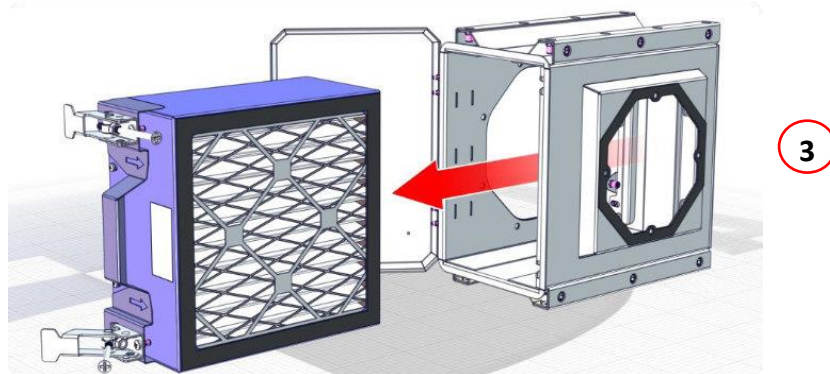
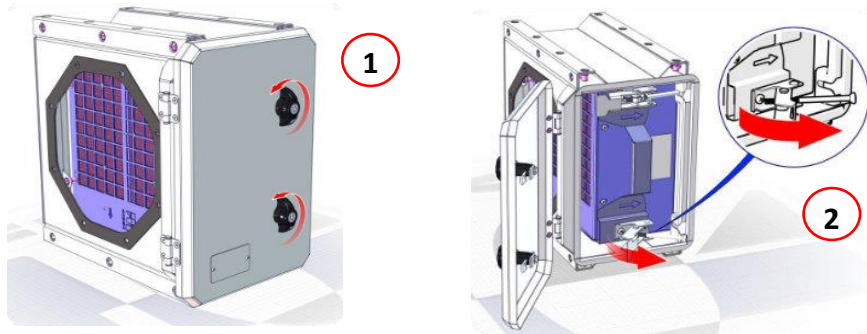

Carbon Filter Service Kit

1. Please follow the steps shown for the Filter Media Carrier Removal, to remove the carrier from the case.
2. Unscrew & remove the 4-off M5 screws (Fig 1)
3. Lift out the solid Media Filter (Fig 2)
4. Lift out the Secondary HEPA Filter (Fig 2)
5. Clean the filter housing of all debris.
6. To refit, assemble the components in reverse order.

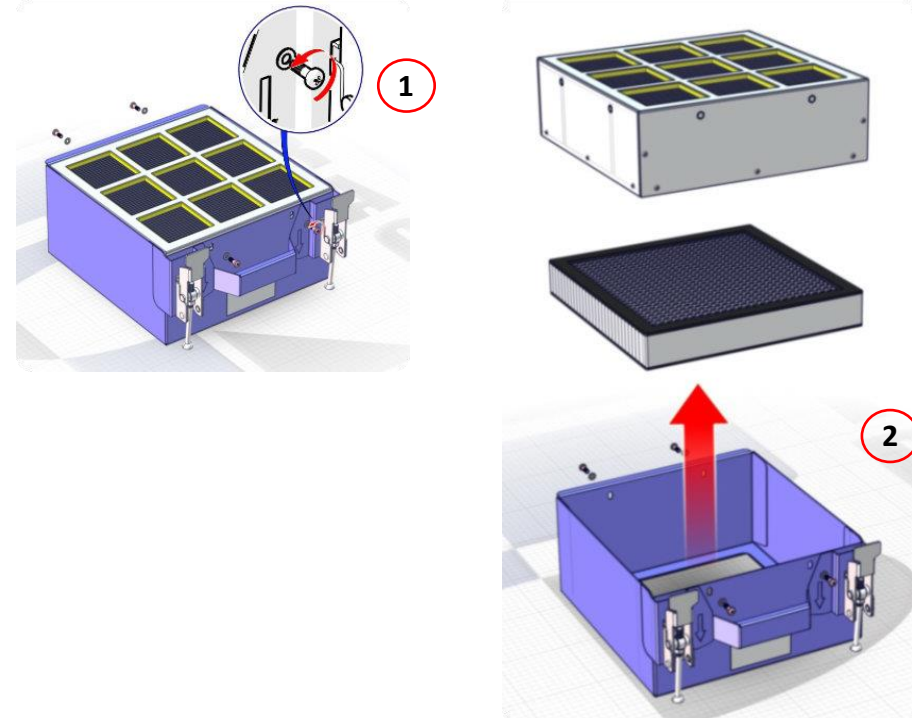

















*** Do not handle until MSDS & all safety precautions have been read and understood. Use personal protective equipment as required.**

Before use, carefully read the product label. Safe work practices are advised to avoid eye or skin contact and inhalation. Observe good personal hygiene, including washing hands before eating. Prohibit eating, drinking, and smoking in contaminated areas. Avoid inhalation. Mechanical extraction ventilation is recommended when the removal of atmospheric contaminants is required. Maintain dust / fume levels below the recommended exposure standard. For small amounts, absorb with sand, vermiculite or similar and dispose of at an approved landfill site.

WARNING	
For Professional Use Only – keep out of reach of children.	
Do not ignite near or around flammable materials.	
Use only in well-ventilated areas, outdoors, and/or with proper respiratory protection.	
Persons with respiratory sensitivity should avoid exposure to any smoke.	
Concentrated smoke may cause severe burns to the skin, eyes, or respiratory system.	
Improper use may result in sufficient inhalation of smoke to cause respiratory tract irritation and lung damage.	
Harmful if swallowed.	
DANGER	
Use only as directed. Do not handle until all safety precautions, including Safety Data Sheet, have been read and understood. The product contains hexachloroethane. Wear protective clothing. If exposed or concerned, get medical advice. Store in a cool, dry, secure location. KEEP OUT OF REACH OF CHILDREN. Dispose of contents/container per location regulations. When used as directed, exposure should be limited and usually poses no hazard because the hexachloroethane is consumed inside the tube as smoke is produced.	
Directions: (Smoke Bomb)	
1	Ensure other workers in close proximity are informed of use. Place on a non-combustible container, away from flammable materials.
2	Place at Blower intake, or upwind of target area, or near centre of space.
3	Orient "Smoke Issues Here" toward air stream, away from surfaces. Place candle on a flame / heat resistance plate – if not it will melt into the plastic surface.
4	Ensure smoke will not create any hazard where it is anticipated to go.
5	Ignite emitter inside the cabin using site approved device i.e., solder torch or 'lighter' and conduct smoke test.
6	Do not touch or hold smoke generator after ignition – item becomes very hot & remains hot after use.
Smoke Emitter Cabin Pressure Leak Test	
1	The pressuriser system is switched on (TEST MODE).
2	Hold the smoke emitter angled down.
3	Ignite emitter using site approved ignitor i.e., solder torch or 'lighter'.
4	When the product ignites, remove the lighter.
5	If the product flames up, blow out the flame.
6	Place the emitter in a non-flammable container and place it inside the cabin at floor level and close the door/windows.
7	Observe smoke leaks to indicate worn-out or broken seal locations. Check leakage points outside the cabin.
8	Do not come into contact with or inhale smoke haze.
9	Wait until the smoke haze completely disperses before re-entering the cabin. Open door to allow sufficient ventilation of smoke prior to entering cabin.

SMOKE EMITTER CABIN PRESSURE LEAK TEST

Link to MSDS: [SMOKE GENERATOR TQ7621AT30S.pdf](#)

Personal Protective Equipment (PPE)	
	Safety glasses must be worn at all times.
	Sturdy footwear with rubber soles must be worn.
	Respiratory protection devices may be required.
	Gloves may be worn.
Pre-Operational Safety Checks	
	Locate and ensure you are familiar with all machine operations and controls.
	Check work area and walkways to ensure no slip/trip hazards are present.
	Ensure the work area is clean and clear of any flammable material & fire extinguish device is present.
Operational Safety Checks	
	Ensure the machine is correctly isolated / immobilized.
	Ensure other persons do not inhale smoke haze.
	Take care and do not place a lit emitter close to a flammable surface.
Ending Operations and Cleaning Up	
	Leave the work area in a safe, clean, and tidy state.
Potential Hazards	
	Falls
	Fumes
	Fire
	May cause cancer
Exposure is highly unlikely when the product is used as directed. Direct contact with the product does not occur.	
Don't	
	Do not use if an open flame is forbidden.
	Never leave the emitter [cabin test] unattended.

*This SWP does not necessarily cover all possible hazards associated with this equipment and should be used in conjunction with other references. It is designed as a guide to be used to compliment training and as a reminder to users prior to equipment use.

Commissioning Procedures

Follow each step of the installation guide that was supplied with the BreatheSafe kit.

Cabin sealing is an integral part of RS20 & ISO 23875; you must ensure that cabin seals are adequate for maintaining positive pressure. In addition, the site (end- user) must have the correct procedure(s) for servicing OPERATOR enclosure seals in a proactive manner rather than reactive. Items such as door and window seals must be in good working order or new seals FITTED before the BreatheSafe system installation.

Touch-screen cabin pressure display/controller Part# 200027:

***System Check Function:** enter the Settings menu option and select “System Check – Set Max.” The minimum BreatheSafe requirement for cabin sealing efficiency is 250 pascals; if this result is not met, it is essential to re-examine and find pressure leaks of the enclosure and apply new sealing measures.

Submission for commissioning procedure as per the diagram below:

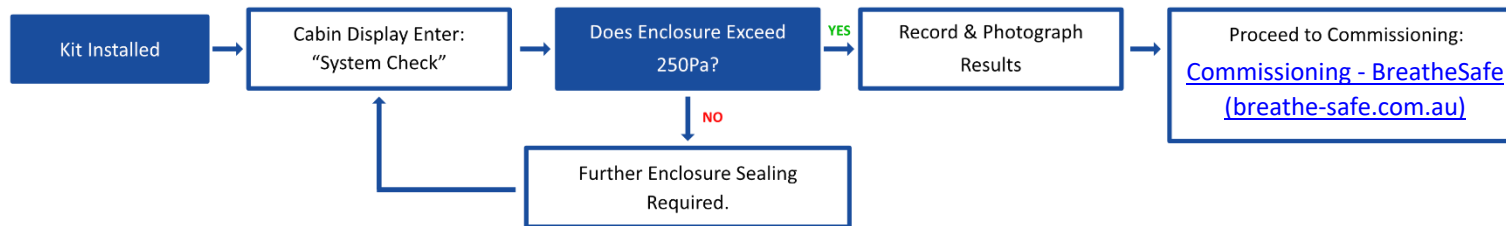

The commissioning images required are:

- ID plate / Machine Serial Number / Asset Number or Call Sign
- INPRESS TL Pressuriser location
- HEPA Return Air Filter Location Option: Powered Return Air Filter
- Cabin Pressure Display Location – Including the “System Check” maximum cabin pressure result with motor output capacity %

Fill in the BreatheSafe Service Tag with the following details:

- Machine Serial Number and Installers details
- Date installed and System Check result (max cabin pressure)
- The set cabin pressure with actual pressure and motor percentage output
- Verify the 250-pascal threshold was achieved = pass OR not achieved = fail**

Please upload machine and installation details in conjunction with the required images. A Commissioning Certificate will be sent to the email address you nominate. **Extended warranty for (RS20 & ISO 23875) BreatheSafe Systems is only applicable to operator enclosures meeting this requirement.

COMMISSIONING PROCEDURES – CABIN PRESSURISER

Wiring Diagram

TECHNICAL DETAILS

PRESSURISER WIRING SCHEMATIC

INPRESS TL CABIN AUTO PRESSURE MONITOR & 12V DC BRUSHLESS BLOWER MOTOR

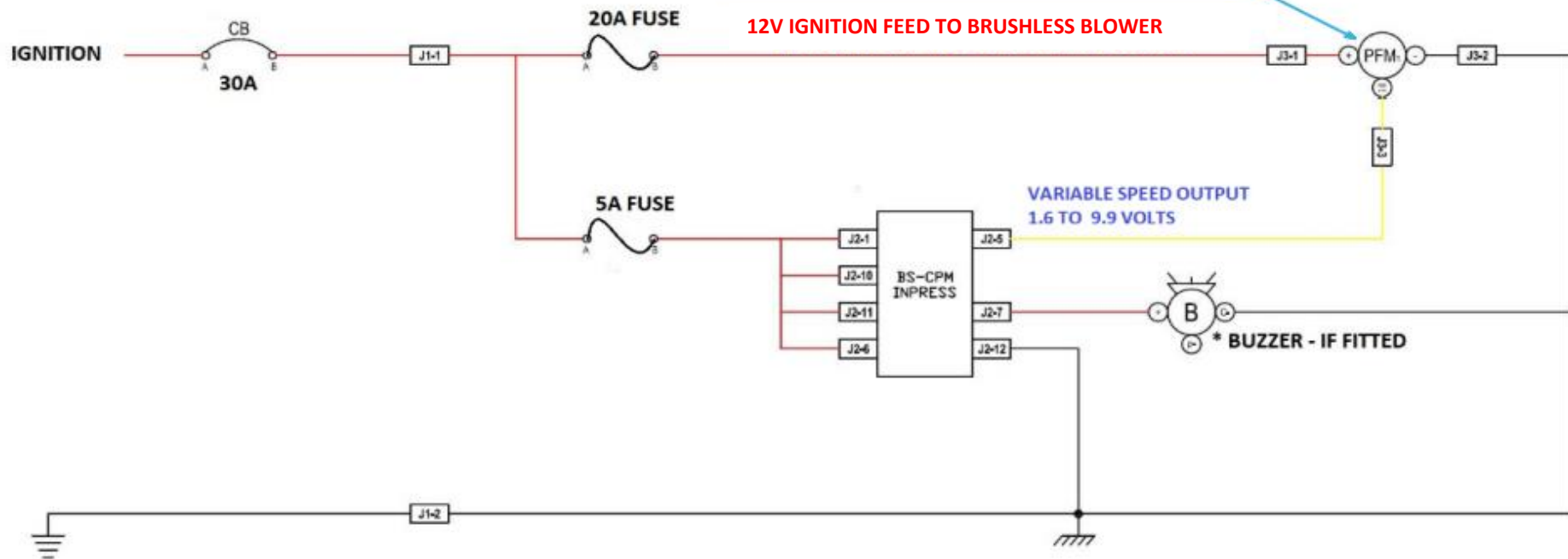
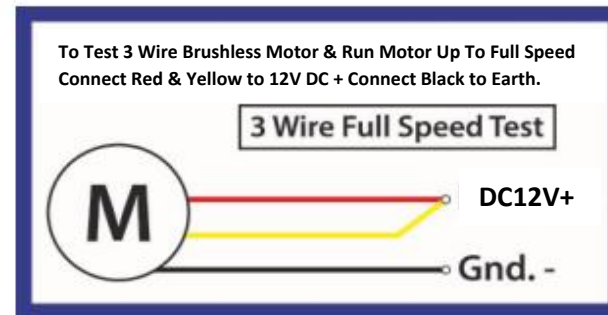

Fault Diagnosis

NOTE: This section is written on the assumption that the tradesperson is qualified in heavy-duty HVAC systems & has a good understanding of cabin fresh air filtration & cabin pressurisation.

They must have a good understanding of the operation of the system prior to fault diagnosis and repairs (If in doubt please ask).

Fault Pressuriser blower is not running

1. Check main circuit breaker or fused power supply. Make sure the motor is receiving the correct power supply with the ignition on & engine running. - 12volts across the red & black wires (Turn on the HVAC fan to speed one)
2. Check that the In-cabin control unit is also receiving 12v across pins 1 & pin 12 at the back of the control unit.
3. With the machine running open one of the doors or windows. Check the voltage on the yellow wire to the fan motor you should have 10v (max speed) if it is not running then test the blower.

Testing of the brushless blower

1. To test the brushless blower – Disconnect it from the main control look (can only be tested when isolated).
2. Supply 12v DC to both the Red & Yellow wires on the motor. Connect the black wire to earth. The motor will now increase speed to full RPM. If it does not increase speed to full RPM then it is faulty.

FAULT DIAGNOSIS – CABIN PRESSURISER

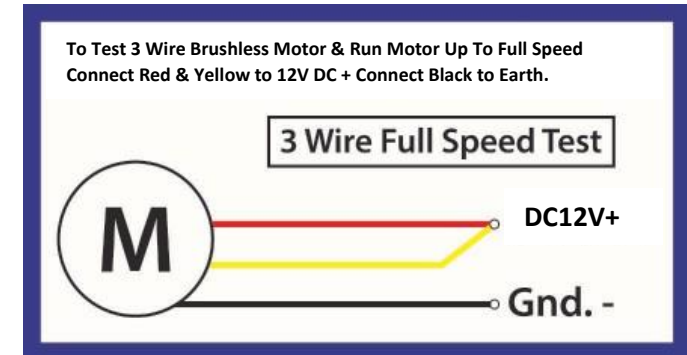

Dust in the cabin – TESTING CABIN SEALING

1. Check filters are they serviceable - if in doubt remove them while testing.
2. Press & hold the down key on the controller for 10 Seconds this will put the unit into test mode (10 volts will be applied to the yellow wire forcing it onto high speed - maximum output)
3. Using a smoke bomb or a smoke machine inspect the cabin for leaks as you find & seal each leak check the pressure, we recommend at least 250 Pa of cabin pressure with all the filters in place. Allow cabin sealants to cure if there are large leakages as overpressure will push through these. Test again and once you have achieved recommended cabin air pressure you can reset the controller by pressing the speaker symbol for 2 seconds.

Note - Ensure all boot, bolts, hoses, cover panels & gaskets have been refitted after the last service/repair.

CABIN PRESSURE TEST

Cabin Sealing Test Procedure

1. Start Engine – Pressuriser is ON.
2. Ensure all windows & doors are CLOSED correctly.
3. Hold down button on INPRESS controller for 10 seconds
*This will force the blower motor onto MAX speed & still display the cabin Pressure.
4. Photograph maximum cabin pressure and include it in the commissioning sheet report.

NOTE: new cabin or a cabin with new seals:

Open a window slightly before closing entrance door to vent static air pressure inside the cabin. When entrance door is fully closed then close the window to begin test.

INPRESS CONTROLLER SERVICE TEST MODE

*TEST WITH NEW FILTER PN TLF700EN



** To exit Service Test Mode, press the Mute button for two seconds.

<p>PROPRIETARY & CONFIDENTIAL The information contained in this drawing is the sole property of BreatheSafe Pty Ltd. Any reproduction in part or as a whole is prohibited without written permission from BreatheSafe Pty Ltd.</p>	<p>Third Angle Projection</p>	<p>TOLERANCES</p> <p>LINEAR : XX. = ±1.50mm XX.X = ±0.75mm XX.XX = ±0.25mm</p> <p>ANGULAR : = ± 0° 30'</p> <p>(Unless Stated on Drawing)</p>		<p>Title: BreatheSafe INPRESS General Arrangement</p>	<p>Dwg No: 03690</p>	<p>Rev: -</p>
		<p>Model: INPRESS</p>	<p>Manufacture: BreatheSafe</p>	<p>Part No: -</p>		
		<p>Material: -</p>	<p>Drawn By: Steve Johnstone</p>	<p>Weight: 0.96 kg</p>	<p>Sheet No: 1 of 1</p>	
		<p>Date: 29/05/2014</p>				

Operating Instructions INPRESS

Users Guide

The BreatheSafe INPRESS unit is a rugged industrial controller, specifically designed to monitor, record, and intelligently control the cabin pressure inside a vehicle's cab.

Efficient cabin pressure management ensures harmful dusts and toxic fumes, cannot ingress into the cab and be inhaled by the operators.



The controller has a built-in 14-bit digital pressure sensor that can accurately measure pressures between -250.0 and +250.0 Pascals with repeatable accuracy.

An alarm set point can be set via the user keypad between the range of 0.0 and 100.0 Pascals. This feature can be accessed by entering the settings menu.

A red L.E.D. alarm, bright even in strong sunlight, is activated if the monitored pressure falls below a user adjustable set point. Appropriate alarm descriptions are displayed on the back lit LCD, allowing effective system diagnostics.

Key Features

- Digital Cabin Pressure Monitoring System
- Data Logger with 10922 record entry
- Intelligent Fan Speed Output with DAC Technology
- Automatic Cabin Pressurisation



CONTROLLER APPEARANCE



ALARM MUTE BUTTON
When an alarm is present, press this button to mute the alarm. The red check LED will remain on whilst the alarm is present.

16X2 ALPHANUMERIC LCD DISPLAY L.E.D. BACK LIT
Displays actual cabin pressure in Pascals on the top line and time and date or any alarms present on the bottom line.

UP BUTTON
This button is only used when setting up the BreatheSafe unit. When pressed it increments values.

BRIGHT L.E.D. ALARM
Illuminates when the cabin pressure drops below the pre-set point. Also, if a door opens or a window opens for more than a pre-set time-period.

REAR CONNECTIONS
This instrument has rear connections for Power, Window Open, Door Open, Normally Open or Normally Closed Volt Free contacts.

DOWN BUTTON
This button is only used when setting up a BreatheSafe unit. When pressed it decrements a value or exits a function.

Operating Instructions

Low Pressure Alarm

If the cabin pressure falls below the pressure Set-point, the bright red alarm L.E.D.  will illuminate. A description of the alarm trigger will be displayed on the LCD to help with diagnostics.

An audible alarm (where fitted) further enhances this safety feature.

The audible alarm may be muted at any time by pressing and holding the Mute button  for 3 seconds.



The Mute button will become valid once all alarms have cleared and a new alarm is triggered

Set up Parameters



Placing the BreatheSafe INPRESS unit into set-up mode allows the adjustment of the following parameters –

- Time (hours, minutes, and seconds)
- Date (day, month, year)
- Pressure Alarm set-point
- Resetting of the data logging
- Calibration and system settings

Enter Set-up Mode

To enter the set-up mode, press and hold the UP  and DOWN  button simultaneously for approximately 5 seconds.



A password screen will appear prompting the entry of a four-digit code.



The code is entered by selecting the UP  key to increment the value from 0 to 9 and back to 0 again. Once the first value is entered, press the DOWN  button to move to the next position. On the last entry press the DOWN  key again and if the code is correct the unit will automatically jump to the Set-Up screen. If the code is incorrect the unit resets and re-starts.



Change Time & Date

Enter Set-up mode. Use the UP and DOWN buttons to cycle to where the display asks - [Change time? Yes or No.](#)



Press the UP  button for Yes or DOWN  for no.



The display will show the time on the top line and the date on the bottom line. Press the UP  button to increase the time variable and press the DOWN  button to skip to the next time or date variable.

Press the MUTE  button at any time to exit this screen and enter the next function.

Change Set-point

Enter Set-up mode. Use the Up and Down buttons to cycle to where the display asks - [Change Set-point? Yes or No.](#)

Press the UP  button for Yes or DOWN  button for no.

The display will show the current pressure Alarm Set-point. Use the UP  or DOWN  keys to increase or decrease the pressure Alarm value from 0.0 up to 100.0 Pascal's. Press the MUTE  button at any time to exit this screen and enter the next function.

Reset Data Log

Enter Set-up mode. Use the UP and DOWN buttons to cycle to where the display asks - [Reset Data Log? Yes or No.](#)



Press the UP  button to reset and the internal pointer back to the beginning of the memory data area. The BreatheSafe INPRESS unit will start to data log from the first memory location once again.

Please note that this feature does not delete the previously recorded data but simply over-writes it. Press the MUTE  button at any time to exit this screen and enter the next function.





Change Calibration (Zero)

Enter Set-up mode. Use the UP and DOWN buttons to cycle to where the display asks - Reset Data Log? Yes or No. Pressing the MUTE  button, will take you to the Zero Calibration screen.

With Zero pressure applied and with both air ports close looped, press the UP  or DOWN  buttons to zero the pressure. The top portion of the display shows the digital value for compensation and the bottom value is the actual pressure reading in Pascals. It is the top value that gets altered.

Once the desired value is entered, press the Mute button to store the new value and move to the next calibration screen, Span Calibration.

Change Calibration (Span)

Apply a pre-set pressure of around 100.0 Pascals to the positive port, ensuring that the negative port is left open to atmosphere and press the UP  or DOWN  buttons to calibrate the pressure Span.

The top portion of the display shows the digital value for compensation and the bottom value is the actual pressure reading in pascals. It is the top value that gets altered.

Please note that the top value provides a dividing ratio for the span calibration and by decreasing that value you actually increase the pressure Span and by increasing the value you decrease the pressure Span. Once the desired value is entered, press the Mute button to store the new value and move to the next screen, Cap Output Volts.

Cap Output Voltage (DAC)

This screen allows the capping of the Digital to Analogue output voltage for Fan Speed Control. This voltage can be set between 5Volts and 10Volts. The lowest control voltage remains as 1.6Volts. If the controller maths calculates that it needs 10Volts output to drive the Fan at full speed to maintain a pre-set cabin pressure and the output has been capped at 6.5Volts, the DAC output will remain at the maximum capped voltage of 6.5Volts regardless.

Under the above circumstances it is possible that the pre-set cabin pressure will not be reached and after a short duration the Low-Pressure Alarm will activate. This feature is factory pre-set and should not be altered as this will be calibrated to indicate 'Dirty Filters'.

Specifications of INPRESS

Input voltage dc	: 12.5V to 36V continuous operation (Regulator is automotive grade – protected against 60V Load Dumps & -50V Reverse Power)
Protection	: Protected against reverse power for an indefinite period of time. No fuses or circuit breakers to replace or reset.
Current at 24Vdc	: Normal operation no alarms = 0.04Amps - With alarms present = 0.08Amps
Display Resolution	: 0.1 Pascal.
Operating Pressure	: -250.0 to +250.0 Pascals linear.
Temperature range	: 0 to 60 °C
Alarm Set point	: 0.0 to 100.0 Pascals - Settable via the user keypad.
Input Pressure	: 14 bits digital pressure sensor (Alarm 30 secs. on delay - 5 secs. off delay).
Window Monitor	: 12/24Vdc = Window closed - 0Vdc = Window open (Alarm 10 secs. delay - 5 secs. off delay).
Door Monitor	: 12/24Vdc = Door Closed - 0Vdc = Door open (Alarm 10 secs. on delay - 5secs. off delay).
Volt Free Output	: N/O & N/C output relay - 125Vac/60Vdc 2A - Isolation between coil and contacts 1000Vac.
Connections	Via 12 way Deutsch connector.
Dimensions	: Fascia 187.5 x 58mm x 3.5mm thick machined aluminum - Depth approximately 60mm without the connector.
Weight	: 480 grams (16.9 ounces)

TECHNICAL DETAILS – INPRESS CONNECTOR PIN-OUT DETAILS

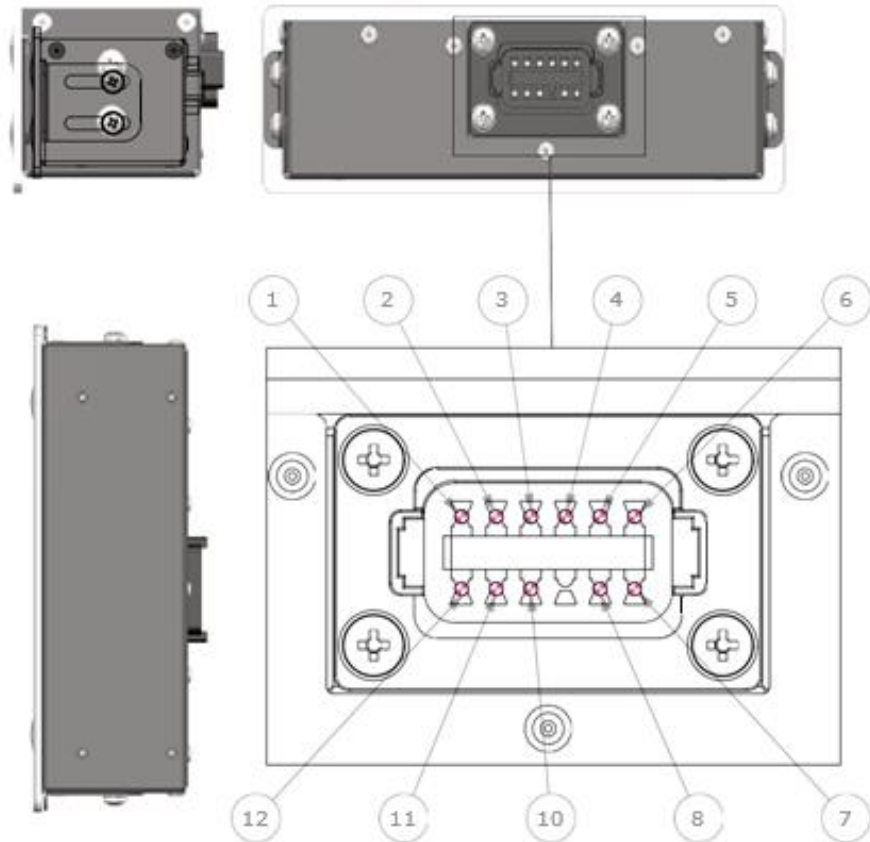

ITEM	PIN	DESTINATION
1	Pin 1	12-23Vdc supply.
2	Pin 2	
3	Pin 3	
4	Pin 4	
5	Pin 5	DAC output for fan speed control
6	Pin 6	Relay Common
7	Pin 7	Relay N/O
8	Pin 8	Relay N/C
10	Pin 9	DOOR + ve input
11	Pin 10	WINDOW + ve input
12	Pin 11	0Vdc supply

INPRESS TL WARRANTY

Express Warranty

All BreatheSafe products carry a warranty against defects in materials or workmanship, provided the defects are not from factors outside of BreatheSafe's control (including neglect, lack of maintenance, improper installation or operation, unauthorized servicing repair, etc.). BreatheSafe will replace goods defected in material or workmanship at our Queensland factory or designated branch*. All parts deemed as failed or faulty must be returned to BreatheSafe for evaluation unless otherwise stated in writing.

Note- Systems must be installed and commissioned as per BreatheSafe installation and commissioning instructions. Once commissioned, the online commissioning sheet must be filled in, extending the components warranty as below. In addition, the system must be serviced and maintained correctly and by trained and qualified personnel. This requisite includes BreatheSafe technicians, qualified automotive air-conditioning technicians, or qualified auto electricians.

Warranty period – Standard

- 1 year or 10,000 hours (whichever occurs first).
- Controllers – 1 year no extended warranty option.
- Warranty Period Extension when commissioning documents are registered online within 28 days of installation
- Extended warranty** only offered if commissioning maximum pressure test reaches at least 250Pa.
- Brushless motor fixed speed two years, or 10,000 hours (whichever occurs first).
- Variable speed brushless motor 15,000 hours, or 3 years** (whichever occurs first).

Must be supplied with a variable speed pressure controller, data download required for 3-year warranty option. Link to online Commissioning and Extended Warranty Registration form <https://www.breathe-safe.com.au/commission/>

What is not covered under Express Warranty?

- Failures are due to incorrect application.
- Damage resulting from neglect, misuse, lack of maintenance, improper installation, or operation, inappropriate or abnormal use, accidental or unauthorized servicing repair.
- Failures are due to parts not being sold or approved by BreatheSafe.
- Failures arising from any other cause that is not directly related to a defect in material or workmanship.

This Express Warranty is VOID if the product is altered, modified, or used in the manner it was not designed for, also including unauthorized repairs, or using maintenance and repair parts other than those supplied by BreatheSafe.

BreatheSafe responsibilities

If there is a defect in material or workmanship not caused by the excluded failures during the warranty period, BreatheSafe will either replace the defective goods at our Queensland factory, or designated branch. *

Alternatively, BreatheSafe may elect to provide new replacement parts, BreatheSafe approved repair parts or assembled components needed to repair the defect. BreatheSafe reserves the right to provide a refund of the purchase price in lieu of replacement or repair at BreatheSafe's discretion. The replacement or repaired product will be sent to you freight prepaid by the customer or made available for pick-up on site.

Users Responsibilities

The customer should ensure that the system is maintained according to BreatheSafe service requirements and only authorized parts must be used to service and maintain BreatheSafe systems. In the event of a suspected warranty claim, BreatheSafe should be contacted in the first instance to arrange the repair or to assist with diagnosis. Claims should be made within one week of the repair.

After contacting BreatheSafe, you may be required to deliver or send the parts to BreatheSafe's Queensland factory or designated branch. * Link to online Warranty claim form <https://www.breathe-safe.com.au/warranty/>

Exclusion and Limitations on Damages and Remedies

This warranty is provided in lieu of all other warranties, written or oral, whether expressed by affirmation, promise, description, drawing, model, or sample. To the extent allowed by law, all warranties other than this warranty, whether express or implied, including implied warranties of fitness for a particular purpose, are disclaimed. The maximum liability of BreatheSafe under this warranty shall not exceed the original purchase price of the product. Interference with the equipment by or abuse, or by operating the equipment at ambient temperatures or with electrical power characteristics outside the ranges indicated in our specification shall be excluded from this warranty, as shall consequential damages.

Excluded from any express warranty are costs incurred in relation to service outside our factory our designated service branch, including traveling time, waiting time, transport costs, mechanical and overtime payments required. As per Australian Consumer Law: You are entitled to choose a refund or replacement for major failures with goods. If a failure with the goods or service does not amount to a major failure, you are entitled to have the failure rectified in a reasonable time. If this is not done, you are entitled to a refund for the goods and to cancel the contract for the service and obtain a refund of any unused portion. You are also entitled to be compensated for any other reasonably foreseeable loss or damage from a failure in the goods or service.

***This express warranty gives you specific legal rights, and you may also have other rights that vary from country to country.**